

Hydraulic Motors & Accessories **K1**

Char-Lynn H Series Geroter Motors Up to 4600 lb-in Intermittent Torque, 1100 Intermittent RPM



Char-Lynn H Series motors are economical, efficient, compact and powerful. They are designed for medium duty applications. These motors have the industry proven spool valve design combined with state-of-the-art gerotors. A wide variety of mounting flanges, shafts, ports and a low speed valving option provides design flexibility. Direction of shaft rotation and shaft speed can be controlled smoothly and easily throughout the speed range of the motor. Equipment can be driven direct, eliminating costly mechanical components.

***Maximum Case Pressure:** 1500 PSI

***Recommended Break-In:** To assure best motor life, run motor for approximately one hour at 30% of rated pressure before application to full load. Be sure the motor is filled with fluid prior to any load applications.

Char-Lynn Model	Sequence #	Displ. (cu.in/rev)	Mounting Flange	Shaft	Ports	Wt.	Price Per Ea
101-1033	176144	2.8	2 Bolt	1 in. Straight Keyed	7/8-14 St. Thd. O-Ring	11.75	\$488.41
101-1009	176116	2.8	4 Bolt	1 in. Straight Keyed	7/8-14 St. Thd. O-Ring	11.75	474.99
101-1001	176100	2.8	4 Bolt	1 in. Straight Keyed	1/2 NPT	11.25	485.73
101-1754	176184	3.6	4 Bolt	1 in. Straight Keyed	1/2 NPT	11.20	470.53
101-1034	176146	4.5	2 Bolt	1 in. Straight Keyed	7/8-14 St. Thd. O-Ring	12.10	525.96
101-1002	176102	4.5	4 Bolt	1 in. Straight Keyed	1/2 NPT	11.50	499.14
101-1035	176148	5.9	2 Bolt	1 in. Straight Keyed	7/8-14 St. Thd. O-Ring	12.34	540.75
101-1027	176136	5.9	2 Bolt	1 in. Straight Keyed	1/2 NPT	12.00	527.31
101-1011	176118	5.9	4 Bolt	1 in. Straight Keyed	7/8-14 St. Thd O-Ring	11.50	527.31
101-1003	176104	5.9	4 Bolt	1 in. Straight Keyed	1/2 NPT	12.00	513.88
101-1028	176138	9.7	2 Bolt	1 in. Straight Keyed	1/2 NPT	13.25	592.08
101-1004	176106	9.7	4 Bolt	1 in. Straight Keyed	1/2 NPT	12.50	594.38
101-1029	176140	11.3	2 Bolt	1 in. Straight Keyed	1/2 NPT	13.50	720.82
101-1013	176120	11.3	4 Bolt	1 in. Straight Keyed	7/8-14 St. Thd O-Ring	13.50	585.01
101-1005	176108	11.3	4 Bolt	1 in. Straight Keyed	1/2 NPT	12.50	619.89
101-1014	176122	14.1	4 Bolt	1 in. Straight Keyed	7/8-14 St. Thd O-Ring	13.00	599.79
101-1006	176110	14.1	4 Bolt	1 in. Straight Keyed	1/2 NPT	13.00	610.49
101-1039	176154	17.9	2 Bolt	1 in. Straight Keyed	7/8-14 St. Thd O-Ring	10.00	648.06
101-1015	176124	17.9	4 Bolt	1 in. Straight Keyed	7/8-14 St. Thd O-Ring	13.00	658.81
101-1007	176112	17.9	4 Bolt	1 in. Straight Keyed	1/2 NPT	13.80	645.39
101-1040	176155	22.6	2 Bolt	1 in. Straight Keyed	7/8-14 St. Thd O-Ring	15.25	708.45
101-1032	176142	22.6	2 Bolt	1 in. Straight Keyed	1/2 NPT	15.50	682.13
101-1016	176126	22.6	4 Bolt	1 in. Straight Keyed	7/8-14 St. Thd O-Ring	15.50	599.87
101-1008	176114	22.6	4 Bolt	1 in. Straight Keyed	1/2 NPT	14.50	735.82

Cha-Lynn Motor Seal Kits

The prefix of Char-Lynn Motors part number indicate the series and the suffix indicates the design number
"H" Series Motor has 101-XXX-OOX Part Number

Part Number	For Series	Our Sequence Number	Price Per Piece
60036	H (Old) -005	BB1005	\$60.94
60023	H-007	BB1010	77.88
60540	H-008, 009, A-001, A-002, A-003	BB1027	88.01

Prices subject to change without notice. **ASK FOR QUANTITY DISCOUNT**

1-800-228-9222 / e-mail: sales@baumhydraulics.com

Fax: 1-800-832-2522 / www.baumhydraulics.com / © Baum Hydraulics Corporation

BAUM HYDRAULICS CORPORATION

K2 Hydraulic Motors & Accessories

Char-Lynn S Series Geroler Motors Up to 5190 lb-in Intermittent Torque, 963 Intermittent RPM



Char-Lynn S Series motors with Geroler offer the same advantage of low speed, high torque and compact size as the H Series geroter. In the Geroler, element precision machined rollers form the displacement chambers. The rollers provide support with rolling contact as the star rotates, minimizing friction and providing high efficiency, especially at start up and at low speeds.

***Maximum Case Pressure:** 1500 PSI

***Recommended Break-In:** To assure best motor life, run motor for approximately one hour at 30% of rated pressure before application to full load. Be sure the motor is filled with fluid prior to any load applications.

Char-Lynn Model	Sequence #	Displ. (cu.in/rev)	Mounting Flange	Shaft	Ports	Wt.	Price Per Ea
103-1537	825088	3.6	2 Bolt	1 in. Straight Keyed	7/8-14 St. Thd. O-Ring	14.80	\$546.53
103-1570	825077	3.6	4 Bolt	1 in. Straight Keyed	7/8-14 St. Thd. O-Ring	12.50	474.22
103-1034	825089	4.6	2 Bolt	1 in. Straight Keyed	7/8-14 St. Thd. O-Ring	15.00	483.86
103-1035	825090	5.7	2 Bolt	1 in. Straight Keyed	7/8-14 St. Thd. O-Ring	15.67	550.00
103-1011	825079	5.7	4 Bolt	1 in. Straight Keyed	7/8-14 St. Thd. O-Ring	14.62	540.07
103-1538	825091	7.3	2 Bolt	1 in. Straight Keyed	7/8-14 St. Thd. O-Ring	16.05	498.32
103-1571	825081	7.3	4 Bolt	1 in. Straight Keyed	7/8-14 St. Thd. O-Ring	14.99	873.63
103-1572	825082	8.8	4 Bolt	1 in. Straight Keyed	7/8-14 St. Thd. O-Ring	15.35	504.10
103-1539	825092	8.8	2 Bolt	1 in. Straight Keyed	7/8-14 St. Thd. O-Ring	16.00	368.94
103-1036	825093	10.1	2 Bolt	1 in. Straight Keyed	7/8-14 St. Thd. O-Ring	17.02	517.59
103-1037	825094	11.4	2 Bolt	1 in. Straight Keyed	7/8-14 St. Thd. O-Ring	12.96	532.05
103-1013	825084	11.4	4 Bolt	1 in. Straight Keyed	7/8-14 St. Thd. O-Ring	16.11	792.99
103-1038	825095	13.7	2 Bolt	1 in. Straight Keyed	7/8-14 St. Thd. O-Ring	20.00	842.63
103-1014	825085	13.7	4 Bolt	1 in. Straight Keyed	7/8-14 St. Thd. O-Ring	16.00	571.57
103-1039	825096	17.9	2 Bolt	1 in. Straight Keyed	7/8-14 St. Thd. O-Ring	20.25	589.88
103-1015	825086	18.2	4 Bolt	1 in. Straight Keyed	7/8-14 St. Thd. O-Ring	18.75	607.23
103-1040	825097	22.7	2 Bolt	1 in. Straight Keyed	7/8-14 St. Thd. O-Ring	20.70	945.94
103-1016	825087	22.7	4 Bolt	1 in. Straight Keyed	7/8-14 St. Thd. O-Ring	20.00	642.90

Cha-Lynn Motor Seal Kits			
The prefix of Char-Lynn Motors part number indicate the series and the suffix indicates the design number "S" Series Motor has 103-XXX-OOX Part Number			
Part Number	For Series	Our Sequence Number	Price Per Piece
60042	S-006, S-005	BB1015	\$80.83
60026	S-007	BB1020	80.18
60533	S-008	BB1025	74.94
60539	S-009, S-010	BB1026	92.15
60564	S-011, R-002, T-001	BB10275	113.85

ASK FOR QUANTITY DISCOUNT Prices subject to change without notice.

BAUM HYDRAULICS CORPORATION

1-800-228-9222 / e-mail: sales@baumhydraulics.com
Fax: 1-800-832-2522 / www.baumhydraulics.com / © Baum Hydraulics Corporation

Hydraulic Motors & Accessories **K3**

Char-Lynn 2000 Series Geroter Motors Up to 8225 lb-in Intermittent Torque, 1042 Intermittent RPM



Char-Lynn 2000 Series motors feature a geroler displacement mechanism that provides high starting and running torque and a smooth output shaft rotation even at very low speeds. A patented pressure-balanced, wear-compensated disc valve maintains minimal leakage as it distributes fluid to the geroler pockets. Heavy duty roller bearings permit high radial loads and are matched to the torque capability of the motor. We have a wide selection of motors, shafts, mounting flanges, ports among others. Call us for assistance.

***Maximum Case Pressure:** 2000 PSI (Without case drain) For continuous back pressure over 2000 PSI, use an external case drain line. Install line so motor case remains full at all times.

***Recommended Break-In:** To assure best motor life, run motor for approximately one hour at 30% of rated pressure before application to full load. Be sure the motor is filled with fluid prior to any load applications.

Char-Lynn Model	Sequence #	Displ. (cu.in/rev)	Mounting Flange	Shaft	Ports	Wt.	Price Per Ea
104-1001	825000	4.9	2 Bolt SAE A	1 in. Straight Keyed	7/8-14 St. Thd. O-Ring	23.03	\$1019.25
104-1022	825014	4.9	2 Bolt SAE A	1-1/4 in. Straight Keyed	7/8-14 St. Thd. O-Ring	23.00	814.18
104-1002	825002	6.2	2 Bolt SAE A	1 in. Straight Keyed	7/8-14 St. Thd. O-Ring	23.35	1000.53
104-1023	825016	6.2	2 Bolt SAE A	1-1/4 in. Straight Keyed	7/8-14 St. Thd. O-Ring	23.59	1000.53
104-1030	825028	6.2	2 Bolt SAE A	SAE C Splined 14T	7/8-14 St. Thd. O-Ring	23.74	1016.59
104-1003	825004	8.0	2 Bolt SAE A	1 in. Straight Keyed	7/8-14 St. Thd. O-Ring	24.11	1043.34
104-1024	825018	8.0	2 Bolt SAE A	1-1/4 in. Straight Keyed	7/8-14 St. Thd. O-Ring	24.25	1043.34
104-1031	825030	8.0	2 Bolt SAE A	SAE C Splined 14T	7/8-14 St. Thd. O-Ring	23.80	846.23
104-1025	825020	9.6	2 Bolt SAE A	1-1/4 in. Straight Keyed	7/8-14 St. Thd. O-Ring	24.50	1048.69
104-1005	825006	11.9	2 Bolt SAE A	1 in. Straight Keyed	7/8-14 St. Thd. O-Ring	25.00	1032.62
104-1026	825022	11.9	2 Bolt SAE A	1-1/4 in. Straight Keyed	7/8-14 St. Thd. O-Ring	25.25	1032.63
104-1065	825050	11.9	2 Bolt SAE A	1-1/4 in. Straight Keyed	1-1/16-12 St.Thd. O-Ring	23.00	1070.09
104-1006	825008	14.9	2 Bolt SAE A	1 in. Straight Keyed	7/8-14 St. Thd. O-Ring	18.00	1055.35
104-1027	825024	14.9	2 Bolt SAE A	1-1/4 in. Straight Keyed	7/8-14 St. Thd. O-Ring	27.00	1055.35
104-1034	825034	14.9	2 Bolt SAE A	SAE C Splined 14T	7/8-14 St. Thd. O-Ring	26.00	880.66
104-1007	825010	18.7	2 Bolt SAE A	1 in. Straight Keyed	7/8-14 St. Thd. O-Ring	27.10	865.47
104-1028	825026	18.7	2 Bolt SAE A	1-1/4 in. Straight Keyed	7/8-14 St. Thd. O-Ring	27.75	1083.47
104-1067	825054	18.7	2 Bolt SAE A	1-1/4 in. Straight Keyed	1-1/16-12 St.Thd. O-Ring	27.75	861.79
104-1143	825060	24.0	2 Bolt SAE A	1 in. Straight Keyed	7/8-14 St. Thd. O-Ring	29.00	1127.59
104-1228	825070	24.0	2 Bolt SAE A	1-1/4 in. Straight Keyed	7/8-14 St. Thd. O-Ring	29.75	1127.59
104-1068	825056	24.0	2 Bolt SAE A	1-1/4 in. Straight Keyed	1-1/16-12 St.Thd. O-Ring	26.00	930.64
104-1229	825072	24.0	2 Bolt SAE A	SAE C Splined 14T	7/8-14 St. Thd. O-Ring	29.50	913.55
104-1420	825080	29.8	2 Bolt SAE A	1-1/4 in. Straight Keyed	7/8-14 St. Thd. O-Ring	32.00	1321.55

Cha-Lynn Motor Seal Kits			
The prefix of Char-Lynn Motors part number indicate the series and the suffix indicates the design number			
"2000" Series Motor has 104 & 105-XXX-OOX Part Number			
Part Number	For Series	Our Sequence Number	Price Per Piece
61252	2000-002, 3, 4, 5	BB1030	\$126.50
61258	2000-006	BB1032	126.82

Prices subject to change without notice. **ASK FOR QUANTITY DISCOUNT**

1-800-228-9222 / e-mail: sales@baumhydraulics.com

Fax: 1-800-832-2522 / www.baumhydraulics.com / © Baum Hydraulics Corporation

BAUM HYDRAULICS CORPORATION

K4**TRW ROSS "TB" SERIES MOTORS**

Use For CHAR-LYNN "H" SERIES OR WHITE "RS" SERIES MOTORS

TB Series Roller Stator Has Two Bronze Bushings and One Needle Thrust Bearing

White Motors and Ross Motors rotate in the same direction as Char-Lynn Motors – All Motors are reversible.

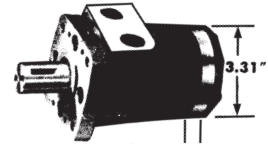
HOW TO IDENTIFY A CHAR-LYNN MOTOR - Measure the width of the gerotor gear just before the end cap of the motor. The width will be either 1/4, 3/8, 1/2, 3/4, 7/8, 1, 1-1/4, 1-1/2, or 2 inches. You can easily identify the motor using the fourth column from the left.

NEW TRW-Ross Motor Number	Our Sequence Number	Price Per Piece	With 1/2" PIPE PORTS				With 7/8" O-RING PORTS	
			Aprox. Disp. Cu.in.	Char-Lynn Gerotor Width	NEW Char-Lynn Motor Number	OLD TRW-Ross Motor Number	NEW Char-Lynn Motor Number	OLD TRW-Ross Motor Number
4-Bolt Light Mounting Flange-1" Straight Shaft with Key								
TB0045FP130AAAB	706958	\$316.15	2			MG 021313AAAB		MG 020913AAAB
TB0050FP130AAAB	706963	432.86	3	1/4	101-1001	MG 031313AAAB	101-1009	MG 030913AAAB
TB0065FP130AAAB	706968	314.22	4	3/8	101-1002	MG 041313AAAB	101-1010	MG 040913AAAB
TB0080FP130AAAB	706969	439.03	5			MG 051313AAAB		MG 050913AAAB
TB0100FP130AAAB	706973	323.86	6	1/2	101-1003	MG 061313AAAB	101-1011	MG 060913AAAB
TB0130FP130AAAB	706974	458.70	8			MG 081313AAAB		MG 080913AAAB
TB0165FP130AAAB	706978	350.85	10	7/8	101-1004	MG 101313AAAB	101-1012	MG 100913AAAB
TB0195FP130AAAB	706983	385.54	12	1	101-1005	MG 121313AAAB	101-1013	MG 120913AAAB
TB0230FP130AAAB	706988	387.47	14	1-1/4	101-1006	MG 141313AAAB	101-1014	MG 140913AAAB
TB0260FP130AAAB	706989	565.11	16			MG 161313AAAB		MG 160913AAAB
TB0295FP130AAAB	706993	356.63	18	1-1/2	101-1007	MG 181313AAAB	101-1015	MG 180913AAAB
TB0330FP130AAAB	706998	603.46	20	2	101-1008	MG 201313AAAB	101-1016	MG 200913AAAB
TB0390FP130AAAB	706995	657.44	24			MG 241313AAAB		
4-Bolt Light Mounting Flange-1" 6 Spline Shaft								
TB0045FP110AAAB	707941	440.58	2			MG 021311AAAB		MG 020911AAAB
TB0050FP110AAAB	707942	403.93	3	1/4		MG 031311AAAB		MG 030911AAAB
-----	-----	-----	4	3/8		MG 041311AAAB		MG 040911AAAB
TB0080FP110AAAB	707944	409.62	5			MG 051311AAAB		MG 050911AAAB
TB0100FP110AAAB	707946	456.38	6	1/2	101-1051	MG 061311AAAB		MG 060911AAAB
TB0130FP110AAAB	707947	427.57	8			MG 081311AAAB		MG 080911AAAB
TB0165FP110AAAB	707948	460.05	10	7/8	101-1052	MG 101311AAAB	101-1060	MG 100911AAAB
TB0195FP110AAAB*	707949	-----	12	1	101-1053	MG 121311AAAB		MG 120911AAAB
TB0230FP110AAAB*	707951	-----	14	1-1/4	101-1054	MG 141311AAAB		MG 140911AAAB
TB0260FP110AAAB	707952	535.28	16			MG 161311AAAB		MG 160911AAAB
-----	-----	-----	20	2	101-1056	MG 201311AAAB	101-1064	MG 200911AAAB
2-Bolt A Mounting Flange-1" Straight Shaft with Key								
TB0045AP130AAAB	707041	431.81	2			MG 021213AAAB		MG 020613AAAB
TB0050AP130AAAB	707043	-----	3	1/4	101-1025	MG 031213AAAB	101-1033	MG 030613AAAB
TB0065AP130AAAB	707048	314.22	4	3/8	101-1026	MG 041213AAAB	101-1034	MG 040613AAAB
TB0080AP130AAAB	707049	-----	5			MG 051213AAAB		MG 050613AAAB
TB0100AP130AAAB	707053	329.64	6	1/2	101-1027	MG 061213AAAB	101-1035	MG 060613AAAB
TB0130AP130AAAB	707054	458.70	8			MG 081213AAAB		MG 080613AAAB
TB0165AP130AAAB	707058	354.70	10	7/8	101-1028	MG 101213AAAB	101-1036	MG 100613AAAB
TB0195AP130AAAB	707063	324.82	12	1	101-1029	MG 121213AAAB	101-1037	MG 120613AAAB
TB0230AP130AAAB	707068	535.99	14	1-1/4	101-1030	MG 141213AAAB	101-1038	MG 140613AAAB
TB0260AP130AAAB	707069	576.39	16			MG 161213AAAB		MG 160613AAAB
TB0295AP130AAAB	707073	550.94	18	1-1/2	101-1031	MG 181213AAAB	101-1039	MG 180613AAAB
TB0330AP130AAAB	707078	414.46	20	2	101-1032	MG 201213AAAB	101-1040	MG 200613AAAB
2-Bolt A Mounting Flange-1" 6 Spline Shaft								
TB0045AP110AAAB	707160	402.83	2			MG 021211AAAB		MG 020611AAAB
TB0050AP110AAAB	707161	403.93	3	1/4	101-1073	MG 031211AAAB		MG 030611AAAB
TB0065AP110AAAB*	707165	-----	4	3/8	101-1074	MG 041211AAAB		MG 040611AAAB
TB0080AP110AAAB	707166	409.62	5			MG 051211AAAB		MG 050611AAAB
TB0100AP110AAAB	707170	417.39	6	1/2	101-1075	MG 061211AAAB	101-1083	MG 060611AAAB
TB0130AP110AAAB	707171	427.57	8			MG 081211AAAB		MG 080611AAAB
TB0195AP110AAAB*	707177	-----	10	7/8	101-1076	MG 101211AAAB	101-1084	MG 100611AAAB
TB0230AP110AAAB*	707180	-----	12	1	101-1077	MG 121211AAAB	101-1085	MG 120611AAAB
TB0260AP110AAAB	707181	-----	14	1-1/4	101-1078	MG 141211AAAB	101-1086	MG 140611AAAB
TB0295AP110AAAB	707185	537.47	16			MG 161211AAAB		MG 160611AAAB
TB0330AP110AAAB	707190	559.91	18	1-1/2	101-1079	MG 181211AAAB	101-1087	MG 180611AAAB
			20	2	101-1080	MG 201211AAAB	101-1088	MG 200611AAAB

ASK FOR QUANTITY DISCOUNT Prices subject to change without notice.**BAUM** HYDRAULICS CORPORATION

1-800-228-9222 / e-mail: sales@baumhydraulics.com

Fax: 1-800-832-2522 / www.baumhydraulics.com / © Baum Hydraulics Corporation

YOUR MEDIUM DUTY HYDRAULIC MOTOR GUIDE

TE Torqmotor Series Dimensions & Shafts

K5

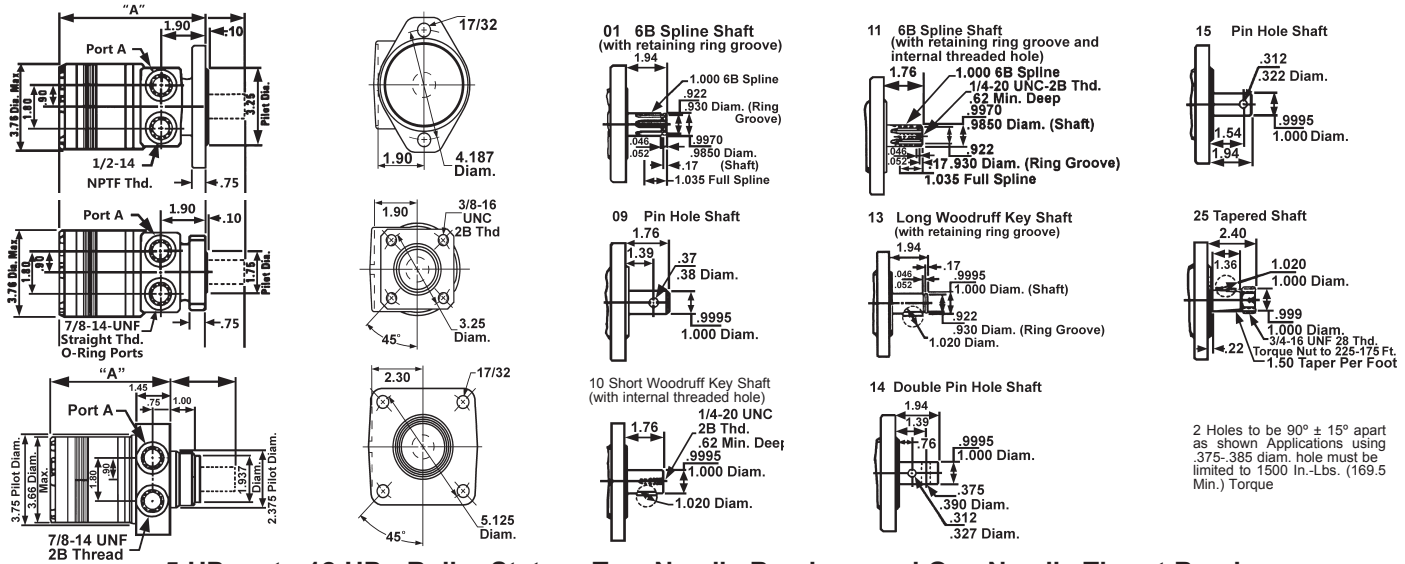

5 HP up to 12 HP - Roller Stator - Two Needle Bearings and One Needle Thrust Bearing

NEW Ross Motor Number	OLD Ross Motor Number	Similar to CharLynn &/or White	Max. PSI	Max. Disp	Max. Torq	Max. Flow	RPM No Load	Max. Cont. PSI	At 5 GPM Max Cont. PSI RPM	HP	HP at 50 RPM Max. Cont. PSI GPM	HP
TE0045FP130AAAA	MF 021313AAAA		2500	2.5	776	9	88	2000	383	3.125	.63	.50
TE0045FP110AAAA	MF 021311AAAA		2500	2.5	776	9	88	2000	383	3.125	.63	.50
TE0045AP130AAAA	MF 021213AAAA		2500	2.5	776	9	88	2000	383	3.125	.63	.50
TE0045AP110AAAA	MF 021211AAAA		2500	2.5	776	9	88	2000	383	3.125	.63	.50
TE0050FP130AAAA	MF 031313AAAA	RSAA1	2500	3	965	12	76	2000	347	3.50	.75	.60
TE0050FP110AAAA	MF 031311AAAA	RSAA6	2500	3	965	12	76	2000	347	3.50	.75	.60
TE0050AP130AAAA	MF 031213AAAA	RSDA1	2500	3	965	12	76	2000	347	3.50	.75	.60
TE0050AP110AAAA	MF 031211AAAA	RSDA6	2500	3	965	12	76	2000	347	3.50	.75	.60
TE0065FP130AAAA	MF 041313AAAA	103-1002 RSAB1	2500	4	1244	15	58	2000	275	3.50	.97	.80
TE0065FP110AAAA	MF 041311AAAA	103-1050 RSAB6	2500	4	1244	15	58	2000	275	3.50	.97	.80
TE0065AP130AAAA	MF 041213AAAA	103-1026 RSDB1	2500	4	1244	15	58	2000	275	3.50	.97	.80
TE0065AP110AAAA	MF 041211AAAA	103-1074 RSDB6	2500	4	1244	15	58	2000	275	3.50	.97	.80
TE0080FP130AAAA	MF 051313AAAA		2500	5	1557	15	45	2000	209	3.50	1.19	1.00
TE0080FP110AAAA	MF 051311AAAA		2500	5	1557	15	45	2000	209	3.50	1.19	1.00
TE0080AP130AAAA	MF 051213AAAA		2500	5	1557	15	45	2000	209	3.50	1.19	1.00
TE0080AP110AAAA	MF 051211AAAA		2500	5	1557	15	45	2000	209	3.50	1.19	1.00
TE0100FP130AAAA	MF 061313AAAA	103-1003 RSAC1	2500	6	1883	15	38	2000	175	3.50	1.40	1.23
TE0100FP110AAAA	MF 061311AAAA	103-1051 RSAC6	2500	6	1883	15	38	2000	175	3.50	1.40	1.23
TE0100AP130AAAA	MF 061213AAAA	103-1027 RSDC1	2500	6	1883	15	38	2000	175	3.50	1.40	1.23
TE0100AP110AAAA	MF 061211AAAA	103-1075 RSDC6	2500	6	1883	15	38	2000	175	3.50	1.40	1.23
TE0130FP130AAAA	MF 081313AAAA		2500	8	2584	15	29	2000	133	3.75	1.85	1.66
TE0130FP110AAAA	MF 081311AAAA		2500	8	2584	15	29	2000	133	3.75	1.85	1.66
TE0130AP130AAAA	MF 081213AAAA		2500	8	2584	15	29	2000	133	3.75	1.85	1.66
TE0130AP110AAAA	MF 081211AAAA		2500	8	2584	15	29	2000	133	3.75	1.85	1.66
TE0165FP130AAAA	MF 101313AAAA	103-1004 RSAE1	2500	10	3291	15	23	2000	108	3.75	2.34	2.00
TE0165FP110AAAA	MF 101311AAAA	103-1052 RSAE6	2500	10	3291	15	23	2000	108	3.75	2.34	2.00
TE0165AP130AAAA	MF 101213AAAA	103-1028 RSDE1	2500	10	3291	15	23	2000	108	3.75	2.34	2.00
TE0165AP110AAAA	MF 101211AAAA	103-1076 RSDE6	2500	10	3291	15	23	2000	108	3.75	2.34	2.00
TE0195FP130AAAA	MF 121313AAAA	103-1005 RSAG1	2500	12	3732	15	19	2000	90	3.75	2.79	2.50
TE0195FP110AAAA	MF 121311AAAA	103-1053 RSAG6	2500	12	3732	15	19	2000	90	3.75	2.79	2.50
TE0195AP130AAAA	MF 121213AAAA	103-1029 RSDG1	2500	12	3732	15	19	2000	90	3.75	2.79	2.50
TE0195AP110AAAA	MF 121211AAAA	103-1077 RSDG6	2500	12	3732	15	19	2000	90	3.75	2.79	2.50
TE0230FP130AAAA	MF 141313AAAA	103-1006 RSAK1	2150	14	3498	20	16	1750	81	3.16	3.20	2.30
TE0230FP110AAAA	MF 141311AAAA	103-1054 RSAK6	2150	14	3498	20	16	1750	81	3.16	3.20	2.30
TE0230AP130AAAA	MF 141213AAAA	103-1030 RSDK1	2150	14	3498	20	16	1750	81	3.16	3.20	2.30
TE0230AP110AAAA	MF 141211AAAA	103-1078 RSDK6	2150	14	3498	20	16	1750	81	3.16	3.20	2.30
TE0260FP130AAAA	MF 161313AAAA	103-1007 RSAM1	1850	16	3462	20	14-1/4	1650	69	2.40	3.60	2.50
TE0260FP110AAAA	MF 161311AAAA	103-1055 RSAM6	1850	16	3462	20	14-1/4	1650	69	2.40	3.60	2.50
TE0260AP130AAAA	MF 161213AAAA	103-1031 RSDM1	1850	16	3462	20	14-1/4	1650	69	2.40	3.60	2.50
TE0260AP110AAAA	MF 161211AAAA	103-1079 RSDM6	1850	16	3462	20	14-1/4	1650	69	2.40	3.60	2.50
TE0295FP130AAAA	MF 181313AAAA		1650	18	3470	20	13	1550	62	2.25	4.60	2.60
TE0295FP110AAAA	MF 181311AAAA		1650	18	3470	20	13	1550	62	2.25	4.60	2.60
TE0295AP130AAAA	MF 181213AAAA		1650	18	3470	20	13	1550	62	2.25	4.60	2.60
TE0295AP110AAAA	MF 181211AAAA		1650	18	3470	20	13	1550	62	2.25	4.60	2.60
TE0330FP130AAAA	MF 201313AAAA	103-1008 RSAP1	1500	20	3427	20	11	1450	55	2.00	4.50	2.70
TE0330FP110AAAA	MF 201311AAAA	103-1056 RSAP6	1500	20	3427	20	11	1450	55	2.00	4.50	2.70
TE0330AP130AAAA	MF 201213AAAA	103-1032 RSDP1	1500	20	3427	20	11	1450	55	2.00	4.50	2.70
TE0330AP110AAAA	MF 201211AAAA	103-1080 RSDP6	1500	20	3427	20	11	1450	55	2.00	4.50	2.70

Prices subject to change without notice. **ASK FOR QUANTITY DISCOUNT**

1-800-228-9222 / e-mail: sales@baumhydraulics.com
 Fax: 1-800-832-2522 / www.baumhydraulics.com / © Baum Hydraulics Corporation

BAUM HYDRAULICS CORPORATION

K6

TRW ROSS "TE" SERIES MOTORS
 Use For CHAR-LYNN "S" SERIES OR WHITE "RS" SERIES MOTORS
 TE Series Roller stator With Two Needle Bearings and One Needle Thrust Bearing
 HOW TO IDENTIFY A CHAR-LYNN "S" TYPE MOTOR

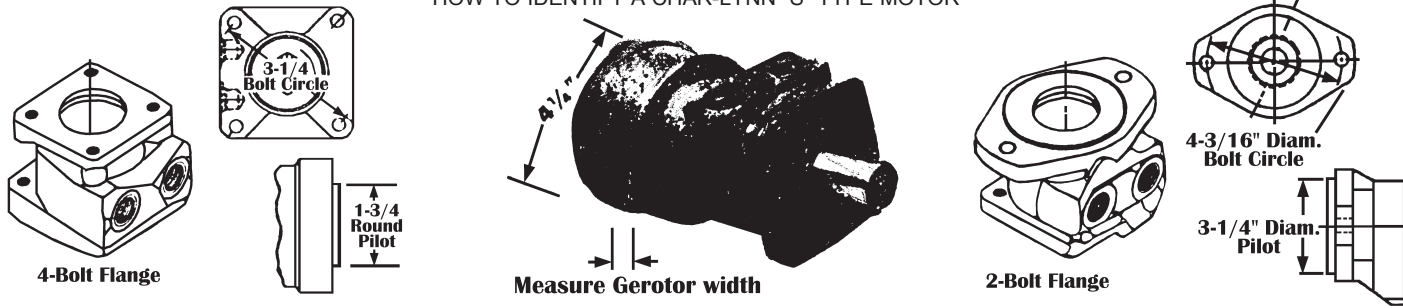

FLOWS FROM 7 to 20 GPM - DISPLACEMENT FROM 3 CU. IN. to 24 CU. IN.
 All Motors are Reversible

TRW-Ross Motor Number	Our Sequence Number	Price Per Piece	With 1/2" PIPE PORTS				With 7/8" O-RING PORTS	
			Approx. Disp. Cu. In.	Char-Lynn Gerotor Width	NEW Char-Lynn Motor Number	OLD TRW-Ross Motor Number	NEW Char-Lynn Motor Number	OLD TRW-Ross Motor Number
4-Bolt Square Light Mounting Flange - 1" Straight Shaft								
TE0045FP130AAAA	707651	\$....	2			MF 021313AAAA		MF 020913AAAA
TE0050FP130AAAA	707652	3			MF 031313AAAA		MF 030913AAAA
TE0065FP130AAAA	707653	537.35	4	3/8	103-1002	MF 041313AAAA	103-1010	MF 040913AAAA
TE0100FP130AAAA	707655	603.48	6	1/2	103-1003	MF 061313AAAA	103-1011	MF 060913AAAA
TE0130FP130AAAA	707656	648.80	8			MF 081313AAAA		MF 080913AAAA
TE0165FP130AAAA	707657	581.21	10	7/8	103-1004	MF 101313AAAA	103-1012	MF 100913AAAA
TE0195FP130AAAA	707658	608.06	12	1	103-1005	MF 121313AAAA	103-1013	MF 120913AAAA
TE0230FP130AAAA	707662	631.72	14		103-1006	MF 141313AAAA	103.1014	MF 140913AAAA
TE0295FP130AAAA	707667	704.62	18			MF 181313AAAA		MF 180913AAAA
TE0330FP130AAAA	707669	795.86	20	2	103-1008	MF 201313AAAA	103-1016	MF 200913AAAA
4-Bolt Square Light Mounting Flange - 1" 6 Spline Shaft								
TE0045FP110AAAA	707698	535.17	2			MF 021311AAAA		MF 020911AAAA
TE0050FP110AAAA	707701	536.26	3			MF 031311AAAA		MF 030911AAAA
TE0080FP110AAAA	707708	578.95	5			MF 051311AAAA		MF 050911AAAA
TE0100FP110AAAA*	707711	6	1/2	103-1051	MF 061311AAAA		MF 060911AAAA
TE0130FP110AAAA	707716	593.51	8			MF 081311AAAA		MF 080911AAAA
TE0165FP110AAAA	707721	594.61	10	7/8	103-1052	MF 101311AAAA	103-1060	MF 100911AAAA
-----	-----	12	1	103-1053	MF 121311AAAA		MF 120911AAAA
TE0230FP110AAAA	707724	631.72	14		103-1054	MF 141311AAAA	103-1062	MF 140911AAAA
TE0260FP110AAAA	707728	694.56	16	1-1/2	103-1055	MF 161311AAAA	103-1063	MF 160911AAAA
TE0295FP110AAAA	707731	704.62	18			MF 181311AAAA		MF 180911AAAA
TE0330FP110AAAA	707730	20	2	103-1056	MF 201311AAAA		MF 200911AAAA
2-Bolt A Mounting Flange - 1" Straight Shaft								
TE0065AP130AAAA	707493	587.36	4	3/8	103-1026	MF 041213AAAA	103-1034	MF 040613AAAA
TE0080AP130AAAA	707494	578.95	5			MF 051213AAAA		MF 050613AAAA
TE0100AP130AAAA	707496	621.59	6	1/2	103-1027	MF 061213AAAA	103-1035	MF 060613AAAA
TE0165AP130AAAA	707500	618.70	10	7/8	103-1028	MF 101213AAAA	103-1036	MF 100613AAAA
TE0195AP130AAAA	707501	664.57	12	1	103-1029	MF 121213AAAA	103-1037	MF 120613AAAA
-----	-----	14		103-1030	MF 141213AAAA	103.1038	MF 140613AAAA
TE0295AP130AAAA*	707504	18			MF 181213AAAA		MF 180613AAAA
TE0330AP130AAAA	707506	735.40	20	2	103-1032	MF 201213AAAA	103-1040	MF 200613AAAA
2-Bolt A Mounting Flange - 1" 6 Spline Shaft								
TE0045AP110AAAA	707619	543.05	2			MF 021211AAAA		MF 020611AAAA
TE0050AP110AAAA	707621	544.15	3			MF 031211AAAA		MF 030611AAAA
TE0065AP110AAAA	707623	545.24	4	3/8	103-1074	MF 041211AAAA	103-1082	MF 040611AAAA
TE0080AP110AAAA	707627	586.84	5			MF 051211AAAA		MF 050611AAAA
TE0100AP110AAAA	707632	587.94	6	1/2	103-1075	MF 061211AAAA	103-1083	MF 060611AAAA
TE0130AP110AAAA	707637	601.39	8			MF 081211AAAA		MF 080611AAAA
TE0165AP110AAAA*	-----	10	7/8	103-1076	MF 101211AAAA	103-1084	MF 100611AAAA
TE0195AP110AAAA	707643	615.96	12	1	103-1077	MF 121211AAAA	103-1085	MF 120611AAAA
TE0230AP110AAAA	707644	639.59	14		103-1078	MF 141211AAAA	103-1086	MF 140611AAAA
TE0260AP110AAAA	707646	702.43	16	1-1/2	103-1079	MF 161211AAAA	103-1087	MF 160611AAAA
TE0295AP110AAAA*	707648	18			MF 181211AAAA		MF 180611AAAA
TE0330AP110AAAA	707650	736.03	20	2	103-1080	MF 201211AAAA	103-1088	MF 200611AAAA

ASK FOR QUANTITY DISCOUNT Prices subject to change without notice. * Special Order From Factory-Call for Price

BAUM HYDRAULICS CORPORATION

1-800-228-9222 / e-mail: sales@baumhydraulics.com
 Fax: 1-800-832-2522 / www.baumhydraulics.com / © Baum Hydraulics Corporation

YOUR HEAVY DUTY HYDRAULIC MOTOR GUIDE

TF Torqmotor Series

K7

TF Torqmotor Series Dimensions

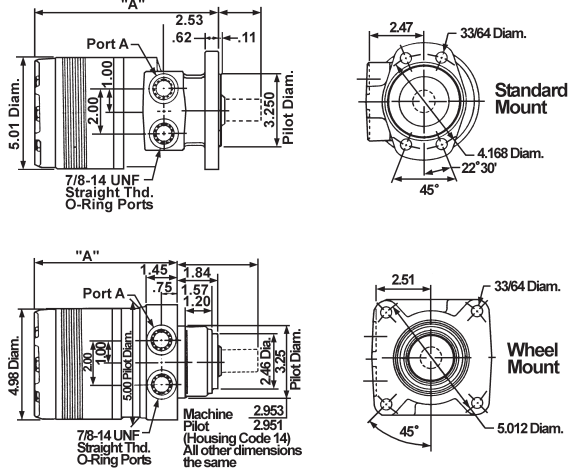

Wheel Mount

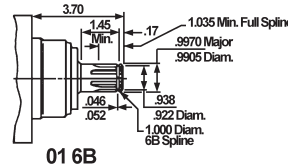

Standard Mount

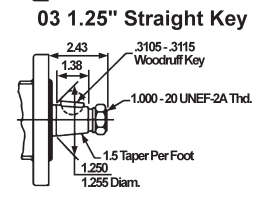
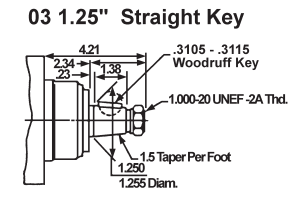
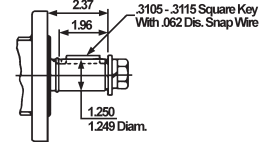
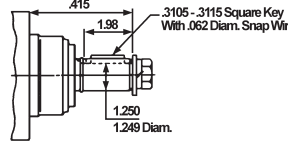
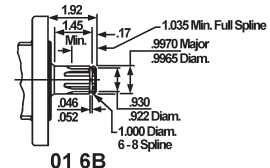

Roller Stator - Two Needle Bearings and Two Needle Thrust Bearings

NEW Ross Motor Number	OLD Ross Motor Number	Similar to CharLynn &/or White	Max. PSI	Disp	Max. Torq	Max. Flow	RPM No Load	Max. Cont. PSI	At 5 GPM Max Cont. RPM	PSI HP	HP at 50 RPM Max. Cont. GPM	PSI HP
TF0080MS020AAAA	MB 050102AAAA	104-1001	4000	5.0	2563	15	47	3000	198	6.00	1.23	1.50
TF0080MS030AAAA	MB 050103AAAA	104-1022	4000	5.0	2563	15	47	3000	198	6.00	1.23	1.50
TF0080MS010AAAA	MB 050101AAAA	104-1015	4000	5.0	2563	15	47	3000	198	6.00	1.23	1.50
TF0080MS050AAAA	MB 050105AAAA		4000	5.0	2563	15	47	3000	198	6.00	1.23	1.50
TF0080MS080AAAA	MB 050108AAAA		4000	5.0	2563	15	47	3000	198	6.00	1.23	1.50
TF0100MS020AAAA	MB 060102AAAA	104-1002	3500	6.0	2760	15	38	2250	180	5.00	1.16	1.60
TF0100MS030AAAA	MB 060103AAAA	104-1023	3500	6.0	2760	15	38	2250	180	5.00	1.16	1.60
TF0100MS010AAAA	MB 060101AAAA	104-1016	3500	6.0	2760	15	38	2250	180	5.00	1.16	1.60
TF0100MS050AAAA	MB 060105AAAA	104-1030	3500	6.0	2760	15	38	2250	180	5.00	1.16	1.60
TF0100MS080AAAA	MB 060108AAAA	104-1009	3500	6.0	2760	15	38	2250	180	5.00	1.16	1.60
TF0130MS020AAAA	MB 080102AAAA	104-1003	3000	7.8	3082	20	30	2000	142	4.50	1.85	1.60
TF0130MS030AAAA	MB 080103AAAA	104-1024	3000	7.8	3082	20	30	2000	142	4.50	1.85	1.60
TF0130MS010AAAA	MB 080101AAAA	104-1017	3000	7.8	3082	20	30	2000	142	4.50	1.85	1.60
TF0130MS050AAAA	MB 080105AAAA	104-1031	3000	7.8	3082	20	30	2000	142	4.50	1.85	1.60
TF0130MS080AAAA	MB 080108AAAA	104-1010	3000	7.8	3082	20	30	2000	142	4.50	1.85	1.60
TF0140MS020AAAA	MB 090102AAAA		3000	8.6	3451	20	27	2000	128	4.50	2.00	1.78
TF0140MS030AAAA	MB 090103AAAA		3000	8.6	3451	20	27	2000	128	4.50	2.00	1.78
TF0140MS010AAAA	MB 090101AAAA		3000	8.6	3451	20	27	2000	128	4.50	2.00	1.78
TF0140MS050AAAA	MB 090105AAAA		3000	8.6	3451	20	27	2000	128	4.50	2.00	1.78
TF0140MS080AAAA	MB 090108AAAA		3000	8.6	3451	20	27	2000	128	4.50	2.00	1.78
TF0170MS020AAAA	MB 100102AAAA	104-1004	3000	10.2	4030	20	22	2000	105	4.50	2.40	2.20
TF0170MS030AAAA	MB 100103AAAA	104-1025	3000	10.2	4030	20	22	2000	105	4.50	2.40	2.20
TF0170MS010AAAA	MB 100101AAAA	104-1018	3000	10.2	4030	20	22	2000	105	4.50	2.40	2.20
TF0170MS050AAAA	MB 100105AAAA	104-1032	3000	10.2	4030	20	22	2000	105	4.50	2.40	2.20
TF0170MS080AAAA	MB 100108AAAA	104-1011	3000	10.2	4030	20	22	2000	105	4.50	2.40	2.20
TF0195MS020AAAA	MB 120102AAAA	104-1005	3000	12.1	4719	20	19	2000	92	4.50	2.80	2.56
TF0195MS030AAAA	MB 120103AAAA	104-1026	3000	12.1	4719	20	19	2000	92	4.50	2.80	2.56
TF0195MS010AAAA	MB 120101AAAA	104-1019	3000	12.1	4719	20	19	2000	92	4.50	2.80	2.56
TF0195MS050AAAA	MB 120105AAAA	104-1033	3000	12.1	4719	20	19	2000	92	4.50	2.80	2.56
TF0195MS080AAAA	MB 120108AAAA	104-1012	3000	12.1	4719	20	19	2000	92	4.50	2.80	2.56
TF0240MS020AAAA	MB 150102AAAA	104-1006	3000	14.6	5992	25	16	2000	75	4.50	3.36	3.00
TF0240MS030AAAA	MB 150103AAAA		3000	14.6	5992	25	16	2000	75	4.50	3.36	3.00
TF0240MS010AAAA	MB 150101AAAA	104-1020	3000	14.6	5992	25	16	2000	75	4.50	3.36	3.00
TF0240MS050AAAA	MB 150105AAAA	104-1034	3000	14.6	5992	25	16	2000	75	4.50	3.36	3.00
TF0240MS080AAAA	MB 150108AAAA	104-1013	3000	14.6	5992	25	16	2000	75	4.50	3.36	3.00
TF0280MS020AAAA	MB 180102AAAA	104-1007	3000	17.7	6941	25	13	2000	64	4.50	3.97	3.57
TF0280MS030AAAA	MB 180103AAAA	104-1028	3000	17.7	6941	25	13	2000	64	4.50	3.97	3.57
TF0280MS010AAAA	MB 180101AAAA	104-1021	3000	17.7	6941	25	13	2000	64	4.50	3.97	3.57
TF0280MS050AAAA	MB 180105AAAA	104-1035	3000	17.7	6941	25	13	2000	64	4.50	3.97	3.57
TF0280MS080AAAA	MB 180108AAAA	104-1014	3000	17.7	6941	25	13	2000	64	4.50	3.97	3.57
TF0405MS020AAAA	MB 250102AAAA		2500	24.7	5800	25	9	1850	40	4.00	6.00	5.00
TF0405MS030AAAA	MB 250103AAAA		2500	24.7	5800	25	9	1850	40	4.00	6.00	5.00
TF0405MS010AAAA	MB 250101AAAA		2500	24.7	5800	25	9	1850	40	4.00	6.00	5.00
TF0405MS050AAAA	MB 250105AAAA		2500	24.7	5800	25	9	1850	40	4.00	6.00	5.00
TF0405MS080AAAA	MB 250108AAAA		2500	24.7	5800	25	9	1850	40	4.00	6.00	5.00

TFXXXXMS020AAAA Std. 7/8 O-Ring Thread Ports 1" Keyed Shaft
 TFXXXXMS030AAAA Std. 7/8 O-Ring Thread Ports 1-1/4" Keyed Shaft
 TFXXXXMS010AAAA Std. 7/8 O-Ring Thread Ports 1" 6 Spline Shaft

TFXXXXMS050AAAA Std. 7/8 O-Ring Thread Ports 1-1/4" 14 Spline Shaft
 TFXXXXMS080AAAA Std. 7/8 O-Ring Thread Ports 1-1/4" Taper Shaft
 Other shaft options are available and normally in stock.

Prices subject to change without notice. **ASK FOR QUANTITY DISCOUNT**

1-800-228-9222 / e-mail: sales@baumhydraulics.com
 Fax: 1-800-832-2522 / www.baumhydraulics.com / © Baum Hydraulics Corporation

BAUM HYDRAULICS CORPORATION

K8**TRW ROSS "TF/TG" SERIES MOTORS**

Use For CHAR-LYNN "2000" SERIES OR WHITE "RE" SERIES MOTORS
 TF/TG Series Roller Stator Has Two Needle Bearings and Two Needle Thrust Bearings

HEAVY DUTY ROLLER GEROTOR TYPE - All Motors are Reversible

Heavy duty roller gerotor motor has double 2-bolt oval flange mount SAE Type A for four 1/2" bolts for stronger and more versatile mounting.

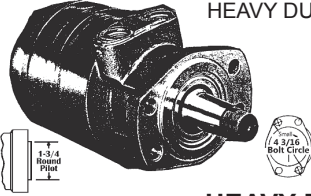

Char-Lynn industrial 2-bolt flange mount for two 1/2" bolts on 4-3/16" bolt circle and 3-1/4" round pilot.

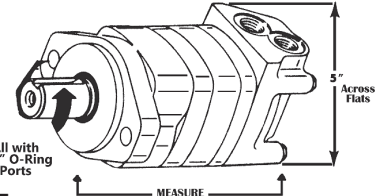
**HEAVY DUTY DOUBLE 2-BOLT MOUNTING FLANGE**

NEW TRW Ross Motor Number	Our Sequence Number	Price Per Piece	Approx. Disp. Cu. In.	Char-Lynn Motor Number	OLD TRW Ross Motor Number	NEW TRW Ross Motor Number	Our Sequence Number	Price Per Piece	Approx. Disp. Cu. In.	OLD TRW Ross Motor Number
2-Bolt A Mounting Flange - 1" Straight Keyed Shaft - 7/8" O-Ring Ports										
TF0080MS020AAAA	706796	\$836.63	5	104-1001	MB 050102AAAA					
TF0100MS020AAAA	706801	723.86	6	104-1002	MB 060102AAAA					
TF0130MS020AAAA	706806	927.23	8	104-1003	MB 080102AAAA					
TF0140MS020AAAA	706807	856.12	9		MB 090102AAAA	TG0140MS020AAAA	707461	\$1068.14	9	ME 090102AAAA
TF0170MS020AAAA	706808	913.82	10	104-1004	MB 100102AAAA	TG0170MS020AAAA	707460	1106.24	10	ME 100102AAAA
TF0195MS020AAAA	706811	753.74	12	104-1005	MB 120102AAAA	TG0195MS020AAAA	707462	1127.58	12	ME 120102AAAA
TF0240MS020AAAA	706813	1071.81	15	104-1006	MB 150102AAAA	TG0240MS020AAAA	707463	1174.76	15	ME 150102AAAA
TF0280MS020AAAA	706816	984.10	18	104-1007	MB 180102AAAA	TG0280MS020AAAA*		18	ME 180102AAAA
-----	-----	-----	23	-----	-----	TG0335MS020AAAA	707465	1194.91	20	ME 210102AAAA
TF0405MS020AAAA	706822	24	104-1143	MB 250102AAAA	TG0405MS020AAAA	707467	1310.50	24	ME 240102AAAA
-----	-----	-----	-----	-----	-----	TG0475MS020AAAA	707466	1544.97	29	ME 290102AAAA
-----	-----	-----	-----	-----	-----	TG0785MS020AAAA	707469	1851.37	48	ME 480102AAAA
2-Bolt A Mounting Flange - 1-1/4" Straight Keyed Shaft - 7/8" O-Ring Port										
TF0080MS030AAAA	706829	896.58	5	104-1022	MB 050103AAAA					
TF0100MS030AAAA	706831	897.83	6	104-1023	MB 060103AAAA					
TF0130MS030AAAA	706836	1036.15	8	104-1024	MB 080103AAAA					
TF0140MS030AAAA	706838	936.30	9		MB 090103AAAA	TG0140MS030AAAA	707329	1144.78	9	ME 090103AAAA
TF0170MS030AAAA	706839	927.23	10	104-1025	MB 100103AAAA	TG0170MS030AAAA*	707330	10	ME 100103AAAA
TF0195MS030AAAA	706841	1051.57	12	104-1026	MB 120103AAAA	TG0195MS030AAAA	707331	12	ME 120103AAAA
TF0240MS030AAAA	706842	946.51	15		MB 150103AAAA	TG0240MS030AAAA	707333	1174.76	15	ME 150103AAAA
TF0280MS030AAAA	706846	774.94	18	104-1028	MB 180103AAAA	TG0280MS030AAAA	707336	1293.97	18	ME 180103AAAA
-----	-----	-----	23	-----	-----	TG0335MS030AAAA	707341	1103.62	21	ME 210103AAAA
TF0405MS030AAAA	706852	1192.09	24	104-1228	MB 250103AAAA	TG0405MS030AAAA	707343	927.23	24	ME 240103AAAA
-----	-----	-----	-----	-----	-----	TG0475MS030AAAA	707346	1913.27	29	ME 290103AAAA
-----	-----	-----	-----	-----	-----	TG0530MS030AAAA	707347	1588.77	33	ME 330103AAAA
-----	-----	-----	-----	-----	-----	TG0785MS030AAAA	707348	2023.15	48	ME 480103AAAA
-----	-----	-----	-----	-----	-----	TG0960MS030AAAA	707351	2327.10	58	ME 580103AAAA
2-Bolt A Mounting Flange - 1" 6 Spline Shaft - 7/8" O-Ring Ports										
TF0080MS010AAAA	706706	820.21	5	104-1015	MB 050101AAAA					
TF0100MS010AAAA	706711	833.66	6	104-1016	MB 060101AAAA					
TF0130MS010AAAA	706716	848.24	8	104-1017	MB 080101AAAA					
TF0140MS010AAAA	706718	917.60	9		MB 090101AAAA	TG0140MS010AAAA	707571	1068.14	9	ME 090101AAAA
TF0170MS010AAAA	706719	852.73	10	104-1018	MB 100101AAAA	TG0170MS010AAAA*		10	ME 100101AAAA
TF0195MS010AAAA	706721	1051.57	12	104-1019	MB 120101AAAA	TG0195MS010AAAA*		12	ME 120101AAAA
TF0240MS010AAAA	706723	871.77	15	104-1020	MB 150101AAAA	TG0240MS010AAAA	707573	1174.76	15	ME 150101AAAA
TF0280MS010AAAA	706726	1081.45	18	104-1021	MB 180101AAAA	TG0280MS010AAAA	707574	1293.50	18	ME 180101AAAA
-----	-----	-----	23	-----	-----	TG0335MS010AAAA	707575	1194.91	21	ME 210101AAAA
TF0405MS010AAAA	706732	1090.59	24		MB 250101AAAA	TG0405MS010AAAA	707577	1336.57	24	ME 240101AAAA
-----	-----	-----	-----	-----	-----	TG0475MS010AAAA	707576	1688.78	29	ME 290101AAAA
2-Bolt A Mounting Flange - 1-1/4" 14 Spline Shaft - 7/8" O-Ring Ports										
TF0080MS050AAAA	706916	722.90	5		MB 050105AAAA					
TF0100MS050AAAA	706921	821.30	6	104-1030	MB 060105AAAA					
TF0130MS050AAAA	706926	848.24	8	104-1031	MB 080105AAAA					
TF0140MS050AAAA	706927	856.12	9		MB 090105AAAA	TG0140MS050AAAA	707386	1068.14	9	ME 090105AAAA
TF0170MS050AAAA*	706928	10	104-1032	MB 100105AAAA	TG0170MS050AAAA	707389	1106.24	10	ME 100105AAAA
TF0195MS050AAAA	706931	1051.57	12	104-1033	MB 120105AAAA	TG0195MS050AAAA	707387	1127.58	12	ME 120105AAAA
TF0240MS050AAAA*	15	104-1034	MB 150105AAAA	TG0240MS050AAAA	707394	1174.76	15	ME 150105AAAA
TF0280MS050AAAA	706936	878.56	18	104-1035	MB 180105AAAA	TG0280MS050AAAA	707396	828.92	18	ME 180105AAAA
-----	-----	-----	23	-----	-----	TG0335MS050AAAA	707401	1194.91	21	ME 210105AAAA
TF0405MS050AAAA	706940	1090.59	24	104-1229	MB 250105AAAA	TG0405MS050AAAA	707402	1310.50	24	ME 240105AAAA
-----	-----	-----	-----	-----	-----	TG0475MS050AAAA	707406	970.61	29	ME 290105AAAA
-----	-----	-----	-----	-----	-----	TG0530MS050AAAA	707407	1787.00	33	ME 330105AAAA
-----	-----	-----	-----	-----	-----	TG0785MS050AAAA	707408	1851.37	48	ME 480105AAAA
-----	-----	-----	-----	-----	-----	TG0960MS050AAAA	707409	2327.10	58	ME 580105AAAA
2-Bolt A Mounting Flange - 1-1/4" Taper Shaft - 7/8" O-Ring Ports										
TF0080MS080AAAA	706763	820.21	5		MB 050108AAAA					
TF0100MS080AAAA	706764	821.30	6	104-1009	MB 060108AAAA					
TF0130MS080AAAA	706771	848.24	8	104-1010	MB 080108AAAA					
TF0140MS080AAAA*	706773	9		MB 090108AAAA					
TF0170MS080AAAA*	10	104-1011	MB 100108AAAA	TG0170MS080AAAA	707304	9	ME 090108AAAA
TF0195MS080AAAA*	706779	12	104-1012	MB 120108AAAA	TG0195MS080AAAA*	707305	12	ME 120108AAAA
TF0240MS080AAAA	706782	871.77	15	104-1013	MB 150108AAAA	TG0240MS080AAAA	707308	1174.76	15	ME 150108AAAA
TF0280MS080AAAA	706787	1081.45	18	104-1014	MB 180108AAAA	TG0280MS080AAAA*	707311	18	ME 180108AAAA
-----	-----	-----	23	-----	-----					
TF0405MS080AAAA	706790	1090.59	24		MB 250108AAAA	TG0405MS080AAAA	707313	1310.50	24	E 240108AAAA
-----	-----	-----	-----	-----	-----	TG0475MS080AAAA	707314	1544.97	29	ME 290108AAAA
-----	-----	-----	-----	-----	-----	TG0530MS080AAAA	707316	1588.76	33	ME 330108AAAA
-----	-----	-----	-----	-----	-----	TG0785MS080AAAA	707317	1851.37	48	ME 480108AAAA
-----	-----	-----	-----	-----	-----	TG0960MS080AAAA	707320	2327.10	58	ME 580108AAAA

ASK FOR QUANTITY DISCOUNT

Prices subject to change without notice. * Special Order From Factory-Call for Price

BAUM HYDRAULICS CORPORATION**1-800-228-9222 / e-mail: sales@baumhydraulics.com**

Fax: 1-800-832-2522 / www.baumhydraulics.com / © Baum Hydraulics Corporation

YOUR VERY HEAVY DUTY & WHEEL MOUNT HYDRAULIC MOTOR GUIDE

TG Torqmotor Series Dimensions

K9

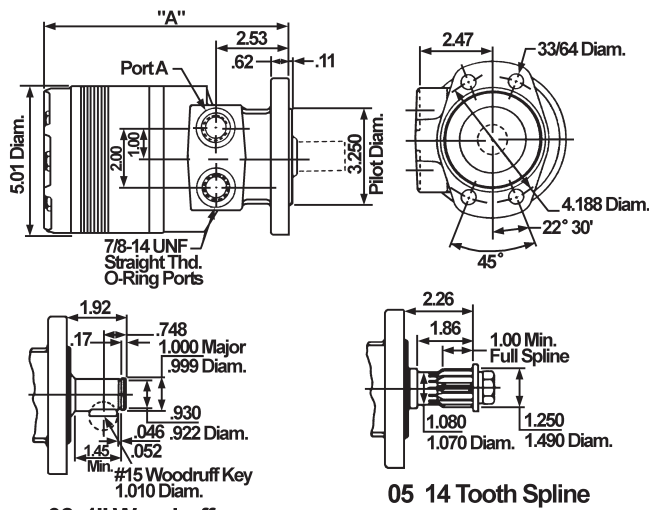

02 1" Woodruff

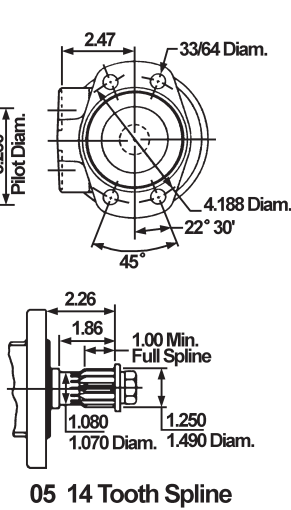

05 14 Tooth Spline

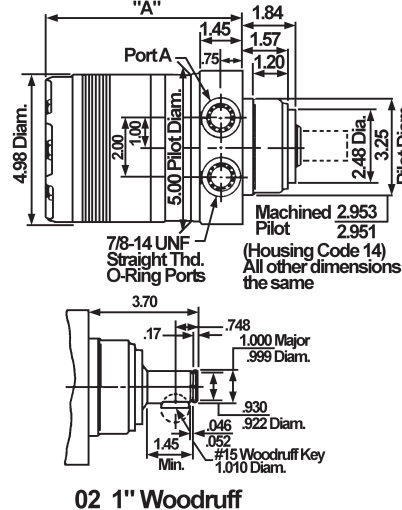

02 1" Woodruff

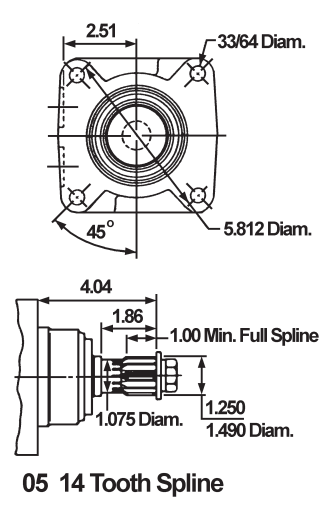

05 14 Tooth Spline

Roller Stator - Two Needle Bearings and Two Needle Thrust Bearings

NEW Ross Motor Number	OLD Ross Motor Number	Similar to CharLynn &/or White	Max. PSI	Disp	Max. Torq	Max. Flow	RPM No Load	Max. Cont. PSI	At 5 GPM Max Cont. RPM	PSI HP	HP at 50 RPM Max. Cont. GPM	PSI HP
TG0140MS030AAAA	ME 090103AAAA		4000	8.6	472.5	25	27	3000	124	6.75	2.10	2.74
TG0140US030AAAA	ME 090203AAAA		4000	8.6	472.5	25	27	3000	124	6.75	2.10	2.74
TG0140MS010AAAA	ME 090101AAAA		4000	8.6	472.5	25	27	3000	124	6.75	2.10	2.74
TG0140MS020AAAA	ME 090102AAAA		4000	8.6	472.5	25	27	3000	124	6.75	2.10	2.74
TG0140MS050AAAA	ME 090105AAAA		4000	8.6	472.5	25	27	3000	124	6.75	2.10	2.74
TG0140MS080AAAA	ME 090108AAAA		4000	8.6	472.5	25	27	3000	124	6.75	2.10	2.74
TG0195MS030AAAA	ME 120103AAAA	RE844	4000	12.1	6434	25	19	3000	87	6.75	3.00	3.90
TG0195US030AAAA	ME 120203AAAA		4000	12.1	6434	25	19	3000	87	6.75	3.00	3.90
TG0195MS010AAAA	ME 120101AAAA	RE842	4000	12.1	6434	25	19	3000	87	6.75	3.00	3.90
TG0195MS020AAAA	ME 120102AAAA	RE846	4000	12.1	6434	25	19	3000	87	6.75	3.00	3.90
TG0195MS050AAAA	ME 120105AAAA	RE845	4000	12.1	6434	25	19	3000	87	6.75	3.00	3.90
TG0195MS080AAAA	ME 120108AAAA	RE843	4000	12.1	6434	25	19	3000	87	6.75	3.00	3.90
TG0240MS030AAAA	ME 150103AAAA		4000	14.6	8154	25	16	3000	72	6.75	3.73	4.75
TG0240US030AAAA	ME 150203AAAA		4000	14.6	8154	25	16	3000	72	6.75	3.73	4.75
TG0240MS010AAAA	ME 150101AAAA		4000	14.6	8154	25	16	3000	72	6.75	3.73	4.75
TG0240MS020AAAA	ME 150102AAAA		4000	14.6	8154	25	16	3000	72	6.75	3.73	4.75
TG0240MS050AAAA	ME 150105AAAA		4000	14.6	8154	25	16	3000	72	6.75	3.73	4.75
TG0240MS080AAAA	ME 150108AAAA		4000	14.6	8154	25	16	3000	72	6.75	3.73	4.75
TG0280MS030AAAA	ME 180103AAAA	RE864	4000	17.7	9619	25	13	3000	61	6.75	4.40	5.50
TG0280US030AAAA	ME 180203AAAA		4000	17.7	9619	25	13	3000	61	6.75	4.40	5.50
TG0280MS010AAAA	ME 180101AAAA	RE862	4000	17.7	9619	25	13	3000	61	6.75	4.40	5.50
TG0280MS020AAAA	ME 180102AAAA	RE866	4000	17.7	9619	25	13	3000	61	6.75	4.40	5.50
TG0280MS050AAAA	ME 180105AAAA	RE865	4000	17.7	9619	25	13	3000	61	6.75	4.40	5.50
TG0280MS080AAAA	ME 180108AAAA	RE863	4000	17.7	9619	25	13	3000	61	6.75	4.40	5.50
TG0335MS030AAAA	ME 210103AAAA	RE874	4000	20.6	11,126	25	11	3000	49.25	6.50	5.49	6.77
TG0335US030AAAA	ME 210203AAAA		4000	20.6	11,126	25	11	3000	49.25	6.50	5.49	6.77
TG0335MS010AAAA	ME 210101AAAA	RE872	4000	20.6	11,126	25	11	3000	49.25	6.50	5.49	6.77
TG0335MS020AAAA	ME 210102AAAA	RE876	4000	20.6	11,126	25	11	3000	49.25	6.50	5.49	6.77
TG0335MS050AAAA	ME 210105AAAA	RE875	4000	20.6	11,126	25	11	3000	49.25	6.50	5.49	6.77
TG0335MS080AAAA	ME 210108AAAA	RE873	4000	20.6	11,126	25	11	3000	49.25	6.50	5.49	6.77
TG0475MS030AAAA	ME 290103AAAA	RE884	3000	29	12,013	30	8	2000	36	4.00	6.70	6.23
TG0475US030AAAA	ME 290203AAAA		3000	29	12,013	30	8	2000	36	4.00	6.70	6.23
TG0475MS010AAAA	ME 290101AAAA	RE882	3000	29	12,013	30	8	2000	36	4.00	6.70	6.23
TG0475MS020AAAA	ME 290102AAAA		3000	29	12,013	30	8	2000	36	4.00	6.70	6.23
TG0475MS050AAAA	ME 290105AAAA	RE885	3000	29	12,013	30	8	2000	36	4.00	6.70	6.23
TG0475MS080AAAA	ME 290108AAAA	RE883	3000	29	12,013	30	8	2000	36	4.00	6.70	6.23
TG0530MS030AAAA	ME 330103AAAA		2500	32.6	10,735	30	7	2000	31.75	4.00	7.75	6.90
TG0530US030AAAA	ME 330203AAAA		2500	32.6	10,735	30	7	2000	31.75	4.00	7.75	6.90
TG0530MS010AAAA	ME 330101AAAA		2500	32.6	10,735	30	7	2000	31.75	4.00	7.75	6.90
TG0530MS050AAAA	ME 330105AAAA		2500	32.6	10,735	30	7	2000	31.75	4.00	7.75	6.90
TG0530MS080AAAA	ME 330108AAAA	RE893	2500	32.6	10,735	30	7	2000	31.75	4.00	7.75	6.90
TG0785MS030AAAA	ME 480103AAAA	RE894	2000	48.1	11,789	30	5	1500	21.75	3.00	11.76	7.30
TG0785US030AAAA	ME 480203AAAA		2000	48.1	11,789	30	5	1500	21.75	3.00	11.76	7.30
TG0785MS050AAAA	ME 480105AAAA	RE895	2000	48.1	11,789	30	5	1500	21.75	3.00	11.76	7.30
TG0785MS080AAAA	ME 480108AAAA		2000	48.1	11,789	30	5	1500	21.75	3.00	11.76	7.30
TG0960US030AAAA	ME 580203AAAA		1500	58	10,954	30	4	1000	20	2.00	13.15	5.40
TG0960MS050AAAA	ME 580105AAAA		1500	58	10,954	30	4	1000	20	2.00	13.15	5.40
TG0960MS080AAAA	ME 580108AAAA		1500	58	10,954	30	4	1000	20	2.00	13.15	5.40

Other shaft options are available and normally in stock.

Prices subject to change without notice. **ASK FOR QUANTITY DISCOUNT**

1-800-228-9222 / e-mail: sales@baumhydraulics.com
 Fax: 1-800-832-2522 / www.baumhydraulics.com / © Baum Hydraulics Corporation

BAUM HYDRAULICS CORPORATION

K10

**TRW ROSS "TF/TG" SERIES
WHEEL MOUNT MOTORS**

VERY HEAVY DUTY WHEEL MOUNT 4-BOLT MOUNTING FLANGE

All Motors are Reversible

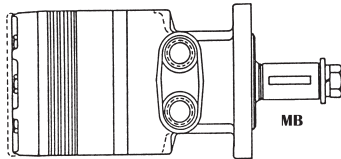

Heavy-duty roller gerotor motor has 4-bolt square wheel mount flange for four 1/2" bolts or 5-13/16" bolt circle with 3-1/4" round pilot that fits DICO wheel hub. This wheel mount motor has 1-1/4" round shaft with straight key and heavy bearings. This wheel mount motor is best for overhung loads like sprockets, pulleys & wheel hubs because the outboard bearing is nearer end of shaft. Wt. 33 lbs.

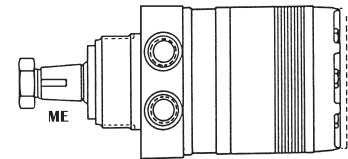

Roller Stator - Both Have Two Needle Bearings and Two Thrust Bearings

NEW TRW Ross Motor Number	Our Sequence Number	Price Per Piece	Approx. Disp. Cu. In.	OLD TRW Ross Motor Number	NEW TRW Ross Motor Number	Our Sequence Number	Price Per Piece	Approx. Disp. Cu. In.	OLD TRW Ross Motor Number
Large 4-Bolt Mounting Flange - Wheel Mount - 1-1/4" Straight Shaft - 7/8" O-Ring Ports									
TF0080US030AAAA	706856	\$1016.87	5	MB 050203AAAA					
TF0100US030AAAA	706861	902.10	6	MB 060203AAAA					
TF0130US030AAAA	706866	1131.57	8	MB 080203AAAA					
TF0140US030AAAA	706867	936.90	9	MB 090203AAAA	TG0140US030AAAA	707356	\$1148.93	9	ME 090203AAAA
TF0170US030AAAA	706868	933.51	10	MB 100203AAAA	TG0170US030AAAA	707358	1187.02	10	ME 100203AAAA
TF0195US030AAAA*		12	MB 120203AAAA	TG0195US030AAAA	707361	1208.37	12	ME 120203AAAA
TF0240US030AAAA	706873	952.56	15	MB 150203AAAA	TG0240US030AAAA	707362	1275.26	15	ME 150203AAAA
-----	-----	18	MB 180203AAAA	TG0280US030AAAA	707366	1264.53	18	ME 180203AAAA
-----	-----	-----	-----	-----	-----	24	ME 240203AAAA
-----	-----	-----	-----	TG0530US030AAAA	707378	1669.54	33	ME 330203AAAA
-----	-----	-----	-----	TG0960US030AAAA	707381	2631.34	58	ME 580203AAAA
Large 4-Bolt Mounting Flange - Wheel Mount - 1-1/4" Splined Shaft - 7/8" O-Ring Port									
TF0080US050AAAA	706891	900.99	5	MB 050205AAAA					
TF0100US050AAAA	706893	966.75	6	MB 060205AAAA					
TF0130US050AAAA	706895	929.02	8	MB 080205AAAA					
TF0140US050AAAA	706896	936.90	9	MB 090205AAAA	TG0140US050AAAA	707417	1148.93	9	ME 090205AAAA
TF0170US050AAAA	706897	933.51	10	MB 100205AAAA	TG0170US050AAAA	707415	1187.02	10	ME 100205AAAA
TF0195US050AAAA	706900	934.60	12	MB 120205AAAA	TG0195US050AAAA	707418	1208.37	12	ME 120205AAAA
TF0240US050AAAA	706902	952.56	15	MB 150205AAAA	TG0240US050AAAA	707419	1255.55	15	ME 150205AAAA
TF0280US050AAAA	706905	959.34	18	MB 180205AAAA	TG0280US050AAAA	707421	1264.53	18	ME 180205AAAA
-----	-----	-----	-----	TG0335US050AAAA	707423	1275.69	21	ME 210205AAAA
TF0405US050AAAA	706911	1171.37	25	MB 250205AAAA	TG0405US050AAAA	707420	1391.29	24	ME 240205AAAA
-----	-----	-----	-----	TG0475US050AAAA	707424	1625.75	29	ME 290205AAAA
Large 4-Bolt Mounting Flange - Wheel Mount - 1-1/4" Tapered Shaft - 7/8" O-Ring Ports									
TF0080US080AAAA	706736	900.99	5	MB 050208AAAA					
TF0100US080AAAA	706741	902.10	6	MB 060208AAAA					
TF0130US080AAAA	706746	929.02	8	MB 080208AAAA					
TF0140US080AAAA	706747	936.90	9	MB 090208AAAA	TG0140US080AAAA*	707287	9	ME 090208AAAA
TF0170US080AAAA	706748	933.51	10	MB 100208AAAA	TG0170US080AAAA	707288	1187.02	10	ME 100208AAAA
TF0195US080AAAA	706751	1147.00	12	MB 120208AAAA	TG0195US080AAAA*	707289	12	ME 120208AAAA
-----	-----	15	MB 150208AAAA	TG0240US080AAAA	707291	1255.55	15	ME 150208AAAA
-----	-----	18	MB 180208AAAA	TG0280US080AAAA*	707293	18	ME 180208AAAA
TF0405US080AAAA	706762	1171.37	25	MB 250208AAAA	TG0405US080AAAA	707296	24	ME 240208AAAA
-----	-----	-----	-----	TG0475US080AAAA	707297	29	ME 290208AAAA
-----	-----	-----	-----	TG0530US080AAAA	707299	1669.54	33	ME 330208AAAA
-----	-----	-----	-----	TG0785US080AAAA*	707301	48	ME 480208AAAA
-----	-----	-----	-----	TG0960US080AAAA*	707302	58	ME 580208AAAA

* Special Order From Factory-Call for Price

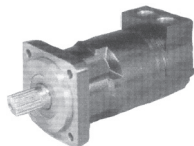

NEW TRW ROSS TK SERIES MOTOR

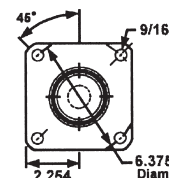

Part Number	Our Sequence Number	Per Each	Similar to Eaton Number	Disp. (cu. in.)	Cont. PSI	Peak PSI	Torq at Cont. PSI & RPM	Torq at Peak PSI & RPM	GPM Cont. Flow	GPM Max. Flow	RPM at Cont. Flow	RPM at Max. Flow
1-1/2" ROUND 4 BOLT WITH 1-5/16 ORING PORTS												
TK0250K5320AAB	707982	\$1712.23	112-1065	15.3	3500	4750	7204 9234	9234	30	35	453	523
TK0315K5320AAB	707984	1745.84	112-1066	19.2	3500	4750	9105 11625	11625	30	35	361	413
TK0400K5320AAB	707986	2253.51	112-1067	24.4	3000	4750	10201 13484	13484	30	40	284	373
TK0500K5320AAB	707988	2090.32	112-1068	30.5	3000	4750	12736 16940	16940	30	40	227	298
TK0630K5320AAB	707990	2135.20	112-1107	38.4	3000	4750	14313 15187	15187	30	40	241	237
TK1000K5320AAB	707992	2666.98	112-1069	61.0	2500	4750	21360 23540	23540	40	60	151	218
1-1/2" - 17 SPLINE 4 BOLT WITH 1-5/16 ORING PORTS												
TK0250K5360AAB	707983	1712.23	112-1059 / 113-1071	15.3	3500	4750	7204 9234	9234	30	35	453	523
TK0315K5360AAB	707985	1745.84	112-1060 / 113-1072	19.2	3500	4750	9105 11625	11625	30	35	361	413
TK0400K5360AAB	707987	1795.21	112-1061 / 113-1073	24.4	3000	4750	10201 13484	13484	30	40	284	373
TK0500K5360AAB	707989	2090.32	112-1062 / 113-1074	30.5	3000	4750	12736 16940	16940	30	40	227	298
TK0630K5360AAB	707991	2135.20	112-1109 / 113-1093	38.4	3000	4750	14313 15187	15187	30	40	241	237
TK1000K5360AAB	707993	2666.98	112-1063 / 113-1075	61.0	2500	4750	21360 23540	23540	40	60	151	218

ASK FOR QUANTITY DISCOUNT Prices subject to change without notice.

BAUM HYDRAULICS CORPORATION

1-800-228-9222 / e-mail: sales@baumhydraulics.com
 Fax: 1-800-832-2522 / www.baumhydraulics.com / © Baum Hydraulics Corporation

DC 12 VOLT MONARCH HYDRAULIC POWER UNITS

K11

500 SERIES SNOW PLOW UNITS & SNOW PLOW SINGLE-ACTING CYLINDERS



M-303

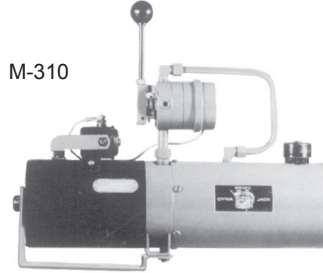

M-310

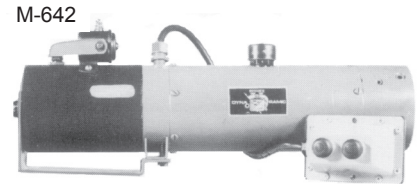

M-642

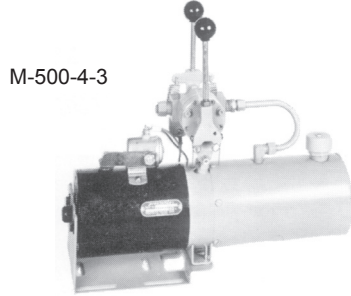

M-500-4-3

M-683

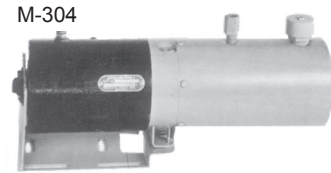
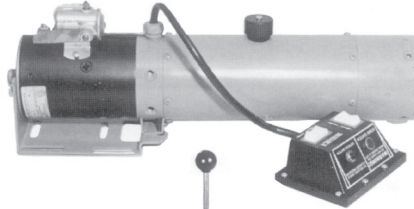

M-304

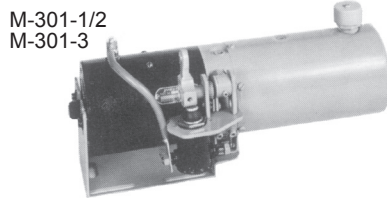

M-301-1/2
M-301-3

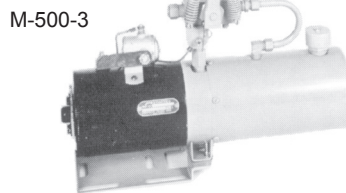

M-500-3

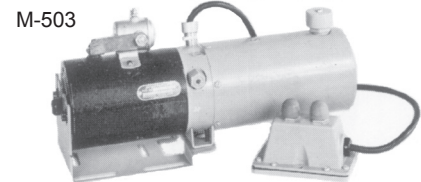

M-503

DC 12 VOLT HYDRAULIC POWER UNITS and SOLENOIDS*

*SOLENOIDS ARE **NOT** RETURNABLE

POWER UNIT				SOLENOID				At 1000 PSI Pressure		At 1500 PSI Pressure		At 2000 PSI Pressure			
Part Number	Our Sequence Number	Price Per Piece	Pump Gear Width Inches	Tank Cap. Gallons	Tank Size, Ins. Ht. x Wt. x Length	Wt. Lbs.	Part Number	Our Sequence Number	Price Per Piece	GPM Output	Amps. Used	GPM Output	Amps. Used	GPM Output	Amps. Used
Pump & Motor with LARGE Tank with 3-way Single-Acting Push-button Operated Solenoid Valve with Cable & Push-button for Gooseneck Hoists, Truck Hoists & Transportation of Farm Implements Can change PSI set screw with locknut. Turn 1 turn for 3000 PSI															
M-303	177676	\$1362.37	3/8	3	10x8x33	35	17757	177608	\$76.65	1-5/8	130	1-1/3	160	3/4	195
Pump & Motor with Tank with 4-way Double-Acting Manual Valve for Tailgates & General Use															
M-310	177678	911.68	3/8	1/2	4-1/2 Rdx10	30	03336	177602	95.84	1-5/8	130	1-1/3	160	3/4	195
Pump & Motor with Tank with 4-way Double-Acting Push-button Operated Solenoid Valve with Six Foot Cable to Push-button for Tailgates, Fork-Lifts, & General Use															
M-642	177687	2323.19	5/16	1/2	4-1/2 Rdx10	35	17757	177608	76.65	1-7/8	115	1-3/8	140	1-1/8	160
Pump & Motor with Tank with 2-way Single-Acting & 4-way Double-Acting Manual Valve for One Single-Acting & One Double-Acting Cylinder OR One Single-Acting & Two Single-Acting Reciprocating Cylinders															
M-500-4-3 w/ SMALL Tank is Standard Snow Plow Pump for Light to Heavy Snow Plows w/ Power Reverse															
M-500-4-3	177684	1/4	1/2	4-1/2 Rdx10	35	17744	177606	69.13	1-5/8	130	1-1/3	160	3/4	195
Pump Motor with Tank with 3-way Single-Acting & 4-way Double-Acting Push-button Operated Solenoid Valve for One Single-Acting & One Double-Acting Cylinder OR One Single-Acting & Two Single-Acting Reciprocating Cylinders with Cross Over Relief and with Six Foot Cable with Push-button Control for Raising & Lowering & Angling Snow Plows															
M-683	177689	1430.86	5/16	1/2	4-1/2 Rdx10	35	03427	-----	1-7/8	115	1-3/8	140	1-1/8	160
Pump & Motor with Tank without Valve															
M-304	177677	602.15	3/8	1/2	4-1/2 Rdx10	30	17757	177608	76.65	2-1/8	130	1-1/3	160	7/8	195
Pump & Motor with SMALL Tank with 3-way Single-Acting Manual Valve for Tailgate Lifts, Pick-up Truck Hoists & Fork-Lifts															
M500-3 is Standard Snow Plow Pump on all Light to Heavy Duty Snow Plows															
M-301-1/2	177669	626.28	3/8	1/2	4-1/2 Rdx10	30	03322	177600	107.38	1-5/8	130	1-1/3	160	3/4	195
M-500-3	177682	668.27	3/8	1/2	4-1/2 Rdx10	35	03336	177602	95.84	1-5/8	130	1-1/3	160	3/4	195
Pump & Motor with LARGE Tank with 3-way Single-Acting Manual Valve M-301-3 for Gooseneck Hoists, Truck Hoists & Transportation of Farm Implements															
M-301-3	177674	1368.00	3/8	3	6-1/4x7x21	35	03322	177600	107.38	1-5/8	130	1-1/3	160	3/4	195
Pump & Motor with SMALL Tank with 3-way Single-Acting Push-button Operated Solenoid Valve with Cable & Push-button Standard Snow Plow Pump for all Light to Heavy Duty Snow Plows															
M-503	177686	827.84	3/8	1/2	4-1/2 Rdx10	35	03336	177602	95.84	1-5/8	130	1-1/3	160	3/4	195

Prices subject to change without notice. **ASK FOR QUANTITY DISCOUNT**

1-800-228-9222 / e-mail: sales@baumhydraulics.com
Fax: 1-800-832-2522 / www.baumhydraulics.com / © Baum Hydraulics Corporation

BAUM HYDRAULICS CORPORATION

K12

HIGH PRESSURE POWER UNITS WITH PISTON PUMPS HYDRAULIC POWER PACKAGES

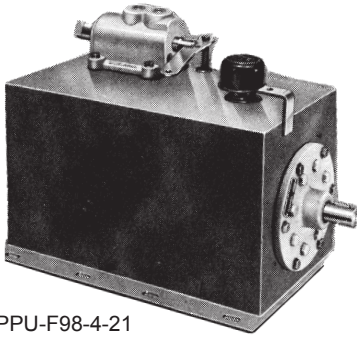

PPU-F98-4-21
PPU-F98-3-21
PPU-D58-6-21

Power Unit with Valve on Top

Integral Power Package Includes pump, valving, reservoir, oil filter & relief valve.

USE: To operate high pressure hoists or a high pressure shop hydraulic press or a high pressure cylinder. For power take-off speed from 300 RPM to 800 RPM for 50 models and 300 RPM to 1000 RPM for all other models. These pumps are very efficient at high pressure operations.

The power units are a complete power package with built-in relief valve, tank, filter and control valve. Remote control ten foot cables are available. Each of the four pump sizes is in a different size tank. The two piston pump is for 3500 PSI operation, and the four and eight piston pumps are for 2500 PSI operation. Rotation either direction. Shaft size 1 inch round for JH 38 adapter. Without valve handle.

WILLIAMS - PUMP ONLY

Part Number	Our Sequence Number	Price Per Piece
H98	177817	\$1013.73

BREATHER CAP FOR WILLIAMS

Part Number	Our Sequence Number	Price Per Piece
1013	177816

CABLE CONTROL UNITS for DASH BOARD

See Page W2 for PTO Cables

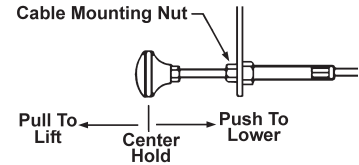

Power Unit Number	Our Sequence Number	Price Per Piece	Control Valve Type	550 RPM		1000 RPM		1600 RPM		1800 RPM	
				GPM Output	HP Input	GPM Output	HP Input	GPM Output	HP Input	GPM Output	HP Input
Small Size 3500 PSI Two Piston Power Unit & 7 Quart Reservoir											
PPU-20-4-7	178181	\$....	With Double-Acting Valve	1	2	2	4	--	--	--	--
PPU-20-3-7	178182	1769.56	With Single-Acting Valve	1	2	2	4	--	--	--	--
Medium Size 2500 PSI Four Piston Power Unit & 15 Quart Reservoir											
PPU-40-4-15	177988	With Double-Acting Valve	2	3	4	6	--	--	--	--
PPU-40-3-15	178048	With Single-Acting Valve	2	3	4	6	--	--	--	--
Large Size 2500 PSI Eight Piston Power Unit & 21 Quart Reservoir											
PPU-F98-4-21	178114	With Double-Acting Valve	4	8	8	15	--	--	--	--
PPU-F98-7-21	178179	With Single-Acting Valve	4	8	8	15	--	--	--	--
High Speed Large Size 2500 PSI Eight Piston Power Unit & 21 Quart Reservoir											
PPU-D58-6-21	178180	3072.89	With Double-Acting Valve	1.7	2.7	3.3	5.3	5.2	8.3	5.9	9.5

SPECIFICATIONS

Power Unit Number	Replacement Pump	Weight Pounds	Port Size Inches	Capacity Quarts	RESERVOIR SIZE		
					Length Inches	Width Inches	Height Inches
PPU-20-4-7	Model 20	40	3/8	4.7	8	8-1/4	8-3/8
PPU-20-3-7	Model 20	40	3/8	4.7	8	8-1/4	8-3/8
PPU-40-4-15	Model 40	53	3/8	7	15-3/8	8-1/4	8-3/8
PPU-40-3-15	Model 40	53	3/8	7	15-3/8	8-1/4	8-3/8
PPU-F98-4-21	Model F98	76	3/8	13.7	17-3/4	9	10
PPU-F98-3-21	Model F98	78	1/2	13.7	17-3/4	9	10
PPU-D58-6-21	Model D58	80	3/8	13.7	17-3/4	9	10

APPROXIMATELY 3-1/2" TO HEIGHT WITH VAVLE

AUTOMATIC "HIGH-LOW" HYDRAULIC SYSTEM

Ideal for Log Splitter and Shop Press - Automatic Two-Stage Hydraulic Pump Unit - DO NOT RUN UNIT OVER 1800 RPM

LOG SPLITTER UNIT

SPECIFICATIONS:

Maximum Pressure:
Log Splitter Unit - Set at 2500 PSI
Shop Press Unit - Set at 5000 PSI

Reservoir Capacity: 21 quarts
Control Valve: 4-way
Shaft Size: 1" Round

Pump produces 6 GPM at 1800 RPM. This provides fast cylinder speed at pressures up to 650 PSI and requires only 2-1/2 HP. When the cylinder load raises the pressure above 650 PSI, the Pilot Unloading Valve will automatically cut out 75% of the oil flow. At this point (1-1/2 GPM), the pump will produce up to 2500 PSI and still require only 2-1/2 HP. When the pressure demand drops, the pump will automatically resume 6 GPM flow.

Minimum Power Source: 2-1/2 HP Electric; 5 HP Gasoline, with speed reduced to 1800 RPM.

Part Number	PSI	Wt. Lbs.	Our Sequence Number	Price Per Piece
PPU-D58X-4E-21	2500	77	177920	\$1288.52

Log Splitter Unit with Pressure Operated Detent

The valve features an automatic return to neutral pressure-operated detent in the return position of the valve.

PPU-D58X-6K-21	2500	81	-----
----------------	------	----	-------	------

SHOP PRESS UNIT

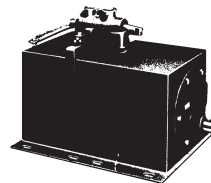

This unit provides the complete system

1. Split Flow Piston Pump
2. Oil Reservoir
3. Directional Control Valve
4. High Pressure Relief Valve
5. Low Pressure Relief Valve
6. Pilot Unloading Valve
7. High Pressure Check Valve

This unit is designed to develop maximum working pressure, but requires only 1/4 the horsepower that a standard hydraulic pump would require at the same working pressure.

Pump produces 6 GPM at 1800 RPM. This provides fast cylinder speed at pressures up to 1250 PSI and requires only 5 HP. When the cylinder load raises the pressure above 1250 PSI, the Pilot Unloading Valve will automatically cut out 75% of the oil flow. At this point (1-1/2 GPM), the pump will produce up to 5000 PSI and still require only 5 HP. When the pressure demand drops, the pump will automatically resume 6 GPM flow.

Minimum Power source: 5 HP Electric; 10 HP Gasoline motor.

Part Number	PSI	Wt. Lbs.	Our Sequence Number	Price Per Piece
PPU-D58X-6-21	5000	83	177925

ASK FOR QUANTITY DISCOUNT Prices subject to change without notice.

BAUM HYDRAULICS CORPORATION

1-800-228-9222 / e-mail: sales@baumhydraulics.com

Fax: 1-800-832-2522 / www.baumhydraulics.com / © Baum Hydraulics Corporation

TRI-POWER HAND PUMP

K13

TRI-POWER HAND PUMP

FOR SINGLE AND DOUBLE ACTING CYLINDERS

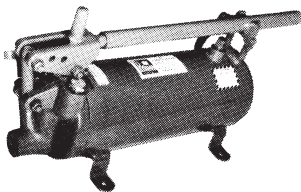

For double-acting cylinders, use Williams detented 4-way valve. The three position, quick change fulcrum gives these flow pressure characteristics:

- Displacement 1-1/4 cu. in. per stroke at 1500 PSI.
- Displacement 1 cu. in. per stroke at 2000 PSI.
- Displacement 2/3 cu. in. per stroke at 3000 PSI.

Based on applied force of 65 lbs. on handle. Replaceable valve seats. Pump can be mounted in vertical or horizontal position. Reservoir capacity, 1 gallon. Breather plug. Ports are 3/8 inch pipe thread. Wt. 30 lbs.

Part Number	Description	Our Sequence Number	Price Per Piece
PMHP-10B	Tri-Power Hand Pump	103788	\$1457.11
PMCK-PMHP10	Seal Kit for PM-HP10	EE2145	15.87

HAND PUMP

SPECIFICATIONS:

- Volume Displacement 1.20 inch full cycle
- Tank size 95 inches
- Pressure rating: 2000 PSI
- Outlet Port Size: #6 SAE (9/16-18)
- Filler Port Size 1/4" NPT

Optional horizontal mounting brackets allows for horizontal handle actuation.

Part Number	Description	Our Sequence Number	Price Per Piece
HP121DA95	Hand Pump	176050	\$602.77

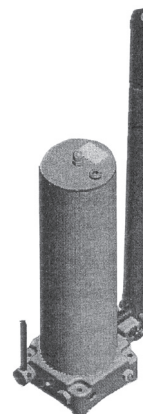

PRINCE STANDARD GEROTOR MOTORS LOW SPEED - HIGH TORQUE

Features: High-torque, low speed with gerotor
Instantly reversible by reversing the flow
Cross-over for many popular models in the market
1.0" keyed shaft
4 bolt flange
1/2 NPTF ports



Applications: Use the CMM series for light to medium duty applications such as grain augers and elevators, slat and sand spreaders, car wash and sweeper brushes, conveyors, winches, scissor lifts, and many others. To assure optimum motor life, run motor for approximately one hour at 30% of rated pressure before application of full load.

Motor Number	Our Sequence Number	Per Each	Displacement IN ³ /REV	Maximum Pressure PSI			Maximum Speed RPM		Wt. Lbs.
				Continuous	Intermittant	Intermittant	Continuous	Intermittant	
CMM50-4RP	100729	\$298.93	3.0	1400	2200	800	1000	12.8	
CMM100-4RP	100730	309.67	6.1	1300	2000	600	750	13.4	
CMM200-4RP	100731	428.64	12.2	1200	1800	300	400	14.5	
CMM300-4RP	100732	268.83	17.9	1000	1600	200	250	15.5	
CMM400-4RP	100733	462.38	24.4	900	1300	125	160	16.7	

MOTOR CROSS REFERENCE

Shaft	Ports	Motor Brand	DISPLACEMENT CU. IN./REV.				
			2.9	6.1	11.7	17.5	23.4
4 Bolt Flange Mounting	Woodruff Keyed	Prince	CMM50-4RP	CMM100-4RP	CMM200-4RP	CMM300-4RP	CMM400-4RP
		Charlyn H	101-1001	101-1003	101-1005	101-1007	101-1008
		Danfoss DH	151-2121	151-2123	151-2126	151-2128	151-2129
		TRW Ross	MG061313	MG061313	MG121313	MG181313	MG201313

Prices subject to change without notice. **ASK FOR QUANTITY DISCOUNT**

1-800-228-9222 / e-mail: sales@baumhydraulics.com

Fax: 1-800-832-2522 / www.baumhydraulics.com / © Baum Hydraulics Corporation

BAUM HYDRAULICS CORPORATION

HOW TO SELECT YOUR TRW ROSS TORQMOTORS HIGH TORQUE LOW SPEED MOTORS

Use **STANDARD** Gerator Motor for 1000 PSI to 2000 PSI Pressure.
Use **MEDIUM** Gerator Motor for 1000 PSI to 2500 PSI Pressure.

Use **HEAVY** Gerator Motor for 1000 PSI to 3000 PSI Pressure.
Use **EXTRA-HEAVY** Gerator Motor for 1000 PSI to 4000 PSI Pressure.

Maximum pressure should be considered extreme usage and for short duration.
The numbers indicate first, second, and third choice motor for the machine you want to drive depending upon your tractors oil output.
REMEMBER that your **TRACTOR** provides the **HORSEPOWER** to drive the motor.

The **DIFFERENT SIZE MOTORS** only turn that **HORSEPOWER** into **MORE TORQUE & LESS SPEED** or **LESS TORQUE & MOTOR SPEED** and just act like a **GEARBOX** and **YOU** are **CHOOSING THE GEAR RATIO**.

Flow in gallons per minute gives you the speed; pressure in PSI gives you the torque. Torque times speed divided by 63025 gives you horsepower. Torque is nearly constant over the pressure range. The Torque is generally 15 to 20% less starting than running. If possible you should start empty (unloaded) and then load the motor.

TG0960 - LIMIT TOP PRESSURE TO 1000 PSI
TF0360 - LIMIT TOP PRESSURE TO 1500 PSI
TE0330, TE0295, TE0260, TB0296, TB0260 - LIMIT TOP PRESSURE TO 1200 PSI

TRW Very Heavy Duty	TRW Heavy Duty	TRW Med. Duty	TRW Std. Duty	Speed Per Gal.at Cont. Rate PSI & RPM per GPM	In. Lbs. Tor-que Per 100 PSI	Under Load Appx. Max. Speed RPM	4" Augers Up to 30 Feet	5" Augers Up to 30 Feet	6" Augers Up to 40 Feet	6" Augers Up to 60 Feet	7" Augers Up to 30 Feet	Elevators with Speed Jack Up to 60 Feet	Elevators with Boot Shaft	Combine Discharge Auger	Blender Mixer	Bale Conveyor	Sprayer Pumps	Post Hose Digger with 9" Auger	Unloader Wagon	Drill Fill Auger	
TG0960				4	691	76															
TG0785				4	582	76															
TG0530				6	416	127															
TG0475				7	366	145															
TG0335				10	278	197															
	TF0360			10	276	200															
		TE0330		11	212	164															
			TB0330	11	213	132															
TG0280				12	235	245															
		TE0295		12	190	186													3		
			TB0295	12	203	149													2		
	TF0280			13	219	257													1		
		TE0260		14	169	206															
			TB0260	14	182	164															
TG0240				14	200	288															
	TF0240			15	189	301														2	
			TB0230	16	170	189															
		TE0230		16	159	243															
TG0195				17	157	349															
		TE0195		18	149	216															
			TB0195	18	145	219															
	TF0195			18	175	275														1	
	TF0170			21	133	315									1						
		TE0165		22	127	259									1						
			TB0165	22	123	263									1						
TG0140				25	115	494			3	3											
	TF0140			26	110	368			3	3		3	3			3					
		TE0130		27	101	320			3	3	2										
			TB0130	27	99	324			3	3	2										
	TF0130			29	99	427	3	3	2	2	1	2	2	2							
		TE0100		35	73	421	3	3	2	2	1			1		2					
			TB0100	36	72	430	3	2	2	1	1			1			2				
	TF0100			36	77	540	3	2	1	1		1	1			1					3
	TF0080			40	64	476	3	2	1	1											
			TB0080	42	61	375	3	2	1												
		TE0080		42	60	501	2	1	1								1				
		TE0065		55	47	660	2	1													2
			TB0065	55	47	497	2	1													
		TE0050		69	36	624	1	1													
			TB0050	71	35	637	1	1													
		TE0045		77	29	690	1														1
			TB0045	79	28	712	1														

ASK FOR QUANTITY DISCOUNT Prices subject to change without notice.

COMMERCIAL HIGH PERFORMANCE SINGLE GEAR PUMPS WITH BUSHING BEARINGS

K15

2 BOLT TYPE AA
2" Round Pilot
3-1/4" Bolt Circle
3-1/4"

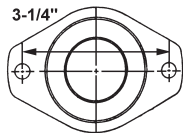

1/2" Rd. Shaft
P5AX95BEAQXX-XX

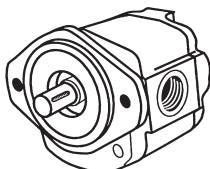

P5, P10, P11 and P17

2 BOLT TYPE A
3-1/4" Round Pilot
4-3/16" Bolt Circle
4-3/16"

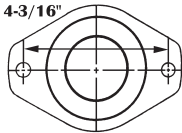

3/4" Rd. Shaft
P11AX93BEAZXX-24
P315A193XX-Spec

5/8" Rd. Shaft
P5AX93BEAQXX-97
P11AX93BEXXXX-97

5/8-9 Spline Shaft
P10AX93BEXXXX-96
P11AX93BEXXXX-96

3/4-11 Spline Shaft
P11AX93BEXXXX-92

2 BOLT TYPE B
4" Round Pilot
5-3/4" Bolt Circle
5-3/4"

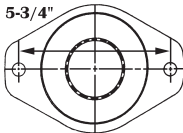

7/8" Rd. Shaft
P330XX97XX-30

1" Rd. Shaft
P330XX97XX-43

7/8-13 Spline Shaft
P330X197XXXX-25

1-1/4" Spline Shaft
P330C497XX-7

4 BOLT TYPE B
4" Round Pilot
5" Bolt Circle

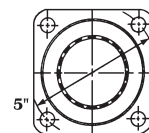

7/8" Rd. Shaft
P330XX42XX-30

1" Rd. Shaft3
P330XX42XX-43

4 BOLT TYPE C
5" Round Pilot
6-3/8" Bolt Circle

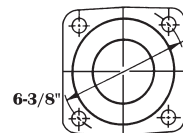

1" Rd. Shaft
P330X178XX-43

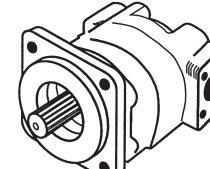

P315 and P330



TO CHANGE ROTATION on P5, P10, P11, P17, P315, P330 pumps you must rotate both thrust plates 180° taking care not to lose the channel seals on the back side of them.. Also rotate the gear housing 180° and rotate the rear port end cover if it is ported. Pumps in this series are positive displacement type used to produce a flow of hydraulic fluid. Flow rate depends on the pump size, the speed at which it is driven and the resistance or pressure it is pumping against.

CUSTOM BUILT PUMPS BUILT FROM PARTS are MORE EXPENSIVE & NON-RETURNABLE

O-Ring Thread, Side Port Pump with 1/2" Round Shaft Part Number	Our Sequence Number	Pump Per Each	O-Ring Thread, Side Port Pump with 1/2" Round Shaft Part Number	Our Sequence Number	Pump Per Each	Max. Speed RPM	Max. Pres- sure PSI	Gallons Output & Horsepower Required at 2000 PSI			
								1200 RPM GPM	1800 RPM HP	1800 RPM GPM	1800 RPM HP
2 BOLT AA MOUNTING						4 BOLT SQUARE MOUNTING					
P5A195BEAQ03-26	CW	J28515	P5A131BEAQ03-26	CW	J28500	4000	4400	.84	1.1	1.26	1.7
P5A295BEAQ06-26	CCW	J28530	P5A231BEAQ06-26	CCW	J28520	3600	4400	1.73	2.3	2.6	3.4
P5A295BEAQ10-26	CCW	J28525	P5A131BEAQ10-26	CW	J28505	2800	4400	2.85	3.6	4.36	5.6
Pump with 5/8" Round Shaft 2 BOLT A MOUNTING						Pump with 5/8-9 Spline Shaft 2 BOLT A MOUNTING					
P5A193BEAQ08-97	CW	J28510	P11A193BEAZ08-96	CW	J29026	3000	4400	2.3	3.0	3.5	4.5
P11A293BEAZ08-97	CCW	J29034	P11A293BEAZ11-96	CCW	J29036	4000	4400	2.3	3.0	3.5	4.5
P11A193BEAZ11-97	CW	J290125	P11A193BEAZ16-96	CW	J290405	3600	4400	3.2	4.1	4.8	6.2
P11A293BEAZ16-97	CCW	J29038	P11A293BEAZ23-96	CCW	J290271	3000	4400	4.6	6.0	6.9	9.0
P11A293BEAZ23-97	CCW	J29041				2800	2750	6.5	8.5	10.9	14.2
Pump with 3/4" Round Shaft 2 BOLT A MOUNTING						Pump with 3/4-11 Spline Shaft 2 BOLT A MOUNTING					
P11A193BEAZ16-24	CW	J29030	P11A193BEAZ16-92	CW	J29016	3000	4400	4.6	6.0	6.9	9.0
P11A193BEAZ23-24	CW	J29032				2800	3500	6.5	8.5	10.9	14.2
Pump with 7/8" Round Shaft 2 BOLT B MOUNTING						Pump with 7/8-13 Spline Shaft 2 BOLT B MOUNTING					
P17A196BEAG25-66	CW	J29044				3300	4000	5.4	7.0	8.2	10.5
						3100	4000	7.1	9.2	10.7	13.8
P17A196MEAB25-66						1-5/16" O-Ring Inlet & 1-1/16" O-Ring Outlet-Rear Ports					
P17A296MEAB25-66	CCW	J2905246				3100	4000	7.1	9.2	10.7	13.8
						3100	4000	7.1	9.2	10.7	13.8
P315 Series ONLY with 3/4" Rd. Shaft O-Ring Thd. SIDE PORT						P315 Series ONLY with 3/4" Rd. Shaft O-Ring Thd. REAR PORT					
P315A193FGAB05	CW	J11990	P315A193UNAB05	CW	J12000	3000	3500	3.0	4.0	4.5	6.0
P315A193FGAB07	CW	J12004	P315A193UNAB07	CW	J12006	3000	3500	4.5	6.0	6.8	9.0
P315A193FGAB10	CW	J12010	P315A193UNAB10	CW	J12014	3000	3500	6.0	8.0	9.0	12.0
P315A193FGAB12	CW	J12016	P315A193UNAB12	CW	J12018	3000	3500	7.5	10.0	11.3	15.0
P315A193FGAB15	CW	J12020	P315A193UNAB15	CW	J12030	3000	3250	9.0	12.0	13.6	18.0
P315A193FGAB17	CW	J12038	P315A193UNAB17	CW	J12040	3000	2900	10.5	14.0	15.8	21.0
P315A193FGAB20	CW	J12050	P315A193UNAB20	CW	J12060	3000	2500	12.0	16.0	18.0	24.0
P315 SERIES CLUTCH PUMPS Using D-7 Clutch						P-5 Clutch rated for 33% more PSI					
P315A189UNAB0756	CW	J06402	P315A289NUAB0756	CCW	J06404	3000	3500	4.5	6.0	6.8	9.0
P315A189UNAB1056	CW	J06412	P315A289NUAB1056	CCW	J06414	3000	3000	6.0	8.0	9.0	12.0
P315A189UNAB1256	CW	J06422	P315A289NUAB1256	CCW	J06424	3000	2500	7.5	10.0	11.3	15.0
P315A189UNAB1556	CW	J06432	P315A289NUAB1556	CCW	J06434	3000	1800	9.0	12.0	13.6	18.0
P315A189UNAB1756	CW	J06438	P315A289NUAB1756	CCW	J06439	3000	1650	10.5	14.0	15.8	21.0
P315A189UNAB2056	CW	J06452	P315A289NUAB2056	CCW	J06454	3000	1500	12.0	16.0	18.0	24.0
P315A195UNAB1056	CW	J06410	P315A295NUAB1056	CCW	J06415	3000	3000	6.0	8.0	9.0	12.0
P315A195UNAB1256	CW	J06420	P315A295NUAB1256	CCW	J06425	3000	2500	7.5	10.0	11.3	15.0
P315A195UNAB1556	CW	J06430	P315A295NUAB1556	CCW	J06435	3000	1800	9.0	12.0	13.6	18.0
P315A195UNAB1756	CW	J06440	P315A295NUAB1756	CCW	J06445	3000	1650	10.5	14.0	15.8	21.0
P315A195UNAB2056	CW	J06450	P315A295NUAB2056	CCW	J06446	3000	1500	12.0	16.0	18.0	24.0

Prices subject to change without notice. **ASK FOR QUANTITY DISCOUNT**

1-800-228-9222 / e-mail: sales@baumhydraulics.com

Fax: 1-800-832-2522 / www.baumhydraulics.com / © Baum Hydraulics Corporation

BAUM HYDRAULICS CORPORATION

K16

COMMERCIAL & TYRONE ELECTRIC CLUTCH FAN BELT PUMPS & DRIVE LINE PUMPS

ORDER PUMP, CLUTCH, and CLUTCH FOOT MOUNT SEPARATELY

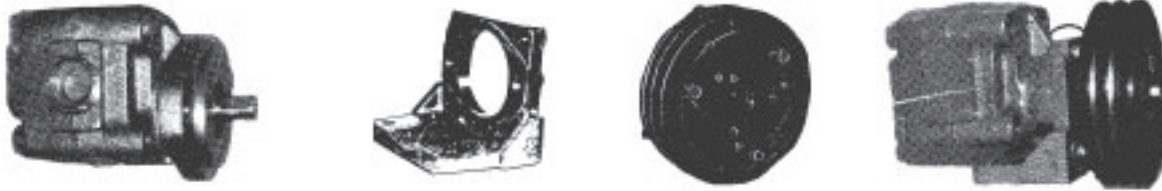

COMMERCIAL PUMP + FOOT MOUNT + CLUTCH = COMPLETE UNIT

How to order: Choose Pump + Adapter Plate (if Tyrone) or Foot Mount (if Commercial) + Clutch

P20 and CP16 Series for Electric Fan Belt 12 Volt Clutch For "A" Belts

Clockwise or Right Hand Rotation LOOKING at the Sheave. ROTATION IS THE RESPONSIBILITY OF THE CUSTOMER.

It is recommended that you use the optional outboard bearing and snap ring on our P20 clutch pumps ONLY.

Tyrone With Pipe Side Ports in Port End Cover Pump ONLY Part Number	Max. Pressure PSI	Commercial Only Pump Part Number	Our Sequence Number	Commercial Price Per Piece	Cubic Inch Per Rev.	Max. Speed RPM	Max. Pressure PSI	Gallons Output & Horsepower Required at Maximum Pressure					
								1200 RPM Speed		1800 RPM Speed		2400 RPM Speed	
								GPM OutPut	HP InPut	GPM OutPut	HP InPut	GPM OutPut	HP InPut
CLOCKWISE STANDARD DUTY CLUTCH rated at 90 Foot Pounds of Torque Clutch Face Points to Front of Engine								USE CLUTCH D-7 Sequence # 589100 \$566.98					
CP16-045-C	3000	P315A195UNAB0756	J06400	\$....	.940	3000	3500	4.5	10.5	6.8	15.7	9	21.0
CP16-065-C	2500	P20A694MEAB07-32	J06310	CALL	1.478	2400	2500	6.75	10.3	10.5	15.4	14.25	20.6
CP16-085-C	1700	P20A694BEIJ10-32	-----	1.970	2400	1700	9	10.5	13.5	15.7	18	21.0
CP16-115-C	1400	P20A694BEIJ12-32	J01812	385.12	2.463	2400	1400	11.5	10.6	16.5	15.8	22	21.1
CP16-150-C	1100	P20A694BEYJ15-32	J05605	395.91	2.955	2400	1100	14	10.6	21	15.8	28	21.1
CP16-180-C	1000	P20A694BEYJ17-32	J01912	CALL	3.448	2400	1000	16	11.0	24	16.5	32	21.9
CP16-200-C	900	P20A694BEYL20-32	J06350	3.940	2400	900	18.5	11.1	27	16.7	36	22.2
27436 Adapter		Foot Mount Bracket Number	308-0001-002		974800								\$134.16
CLOCKWISE MEDIUM DUTY CLUTCH rated at 120 Foot Pounds of Torque Clutch Face Points to Front of Engine								USE CLUTCH P-5 Sequence # 589110 \$676.42					
CP16-045-C	3000	P315A195UNAB0756	J06400940	3000	3500	4.5	10.5	6.8	15.7	9	21.0
CP16-065-C	3000	P20A694MEAB07-32	J06310	CALL	1.478	2400	3000	6.75	12.3	10.5	18.5	14.25	24.7
CP16-085-C	2200	P20A694BEIJ10-32	J05108	1.970	2400	2200	9	13.6	13.5	20.4	18	27.2
CP16-115-C	1800	P20A694BEIJ12-32	J01812	385.12	2.463	2400	1800	11.5	13.6	16.5	20.4	22	27.2
CP16-150-C	1400	P20A694BEYJ15-32	J05605	395.91	2.955	2400	1400	14	13.4	21	20.2	28	26.9
CP16-180-C	1250	P20A694BEYJ17-32	J01912	CALL	3.448	2400	1250	16	13.7	24	20.6	32	27.4
CP16-200-C	1100	P20A694BEYL20-32	J06350	3.940	2400	1100	18.5	13.6	27	20.4	36	27.2
27436 Adapter		Foot Mount Bracket Number	308-0001-002		974800								\$134.16
COUNTER-CLOCKWISE HEAVY DRIVE LINE CLUTCH rated at 200 Foot Pounds of Torque Clutch Face Points to Rear of Engine								USE CLUTCH H-1 Sequence # 589120 \$2490.47					
CP16-045-C	3000	P315A195UNAB0756	J06400	\$....	.940	3000	3500	4.5	10.5	6.8	15.7	9	21.0
CP16-045-A	3000	P315A195UNAB0756	J06400940	3000	3500	4.5	10.5	6.8	15.7	9	21.0
CP16-065-A	3000	P20A694MEAB07-32	J06310	CALL	1.478	2400	3000	6.75	12.3	10.5	18.5	14.25	24.7
CP16-085-A	3000	P20A694BEIG10-32	J05110	1.970	2400	3000	9	18.5	13.5	27.8	18	37.0
CP16-115-A	3000	P20A694BEIG12-32	J01813	2.463	2400	3000	11.5	22.6	16.5	34.0	22	45.3
CP16-150-A	2400	P20A694BEYG15-32	J05605	395.91	2.955	2400	2400	14	23.0	21	34.6	28	46.1
CP16-180-A	2100	P20A694BEYG17-32	J018135	3.448	2400	2100	16	23.0	24	34.6	32	46.1
CP16-200-A	1900	P20A694BEYL20-32	J06350	3.940	2400	1900	18.5	23.5	27	35.2	36	46.9
		Foot Mount Bracket Number	308-0001-002		974800								\$134.16

Outboard Bearing Number 391-0381-040

975750 \$46.23

Snap Ring Number 391-2686-063

975905

\$3.31

PLEASE NOTE: Careful break-in of the clutch unit will enable the clutch to carry it's full load and will give much improved life. To break in the clutch, after installing the unit, ready to go, full of oil, start it up without any load and switch the clutch in and off repeatedly about 100 times. Each morning before working the unit, switch it on and off about 10 to 20 times without any load on it. This will allow the clutch to transmit the maximum torque. To develop full Torque the Clutch must have 12 volts minimum. Be sure your wiring is heavy duty to prevent voltage drop.

ELECTRIC CLUTCHES FOR 4:1 TAPER SHAFT PUMPS

Clutch Number	Our Sequence Number	Per Each	Rotation	Voltage (DC)	A	X	Y	B	C	E Degrees	Belt Groove Type	Current Draw Amps	Resistance Ohms	Gage Line	Static Torque L.b Ft.
VEE BELT CLUTCH FOR 4:1 TAPER SHAFT PUMPS & TWO A BELTS															
P-5	589110	\$....	CW	12	6.70	.87	.62	2.54	.50	36	2-A	4.95	2.423	.841	120
D-12	589105	453.99	CW	12	6.00	.87	.62	2.54	.50	36	2-A	4.95	2.428	.841	90
D-7	589100	CW	12	7.12	.91	.62	2.54	.50	36	2-A	4.36	2.752	.841	90
200 FT-LB DRIVELINE CLUTCH FOR 4:1 TAPER SHAFT PUMPS & YOKE															
H-1	589120	CCW	12				3.72				4.58	2.620		200
120 FT-LB WARNER CLUTCH WITH SERPENTINE GROOVES															
1417-11	589130	CW	12				5.75			6				120
1417-42	589140	CW	12				6.00			8				100

HEAVY DUTY Clutches have a double row bearing. STANDARD DUTY Clutches have a single row bearing.

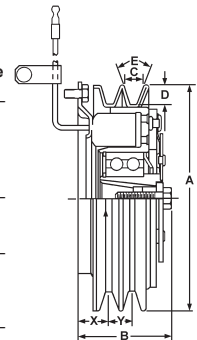

ASK FOR QUANTITY DISCOUNT

Prices subject to change without notice.

BAUM HYDRAULICS CORPORATION

1-800-228-9222 / e-mail: sales@baumhydraulics.com

Fax: 1-800-832-2522 / www.baumhydraulics.com / © Baum Hydraulics Corporation

COMMERCIAL HIGH PERFORMANCE DUMP PUMPS

K17



MOUNTING BRACKET SOLD SEPARATELY

Dual Shaft
1" Round Shaft
for PTO Drive

4 Bolt Type B
4" Round Pilot
5" Bolt Circle
7/8"-13 Spline
Single Shaft

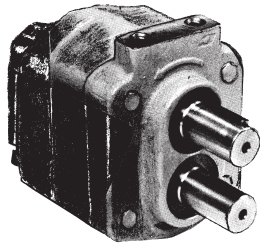

C151-20

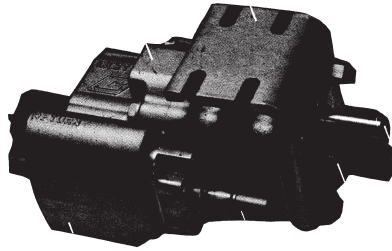

**C101D-20
C101D-25**

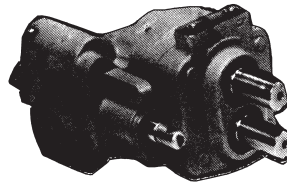

**G101-2-15
G101-2-20**

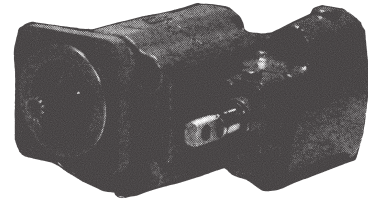

**G102-2-15*
G102-2-20*
C102D-20-1*
C102D-25-1***

TO CHANGE ROTATION on G102 and C102 rotate the gear housing 180° & rotate the valve body 180°. You do not have to rotate the thrust plates in the G102 and C102 as they are bi-rotation thrust plates but be careful not to lose the pocket seal pieces on the back side of them.

Part Number	Our Sequence Number	Price Per Piece	Shaft	Left Port and Right Port	Port Location	Rotation	Max. Speed RPM	Max. Pressure PSI	Gallons Output & Horsepower Required at 2000 PSI			
									1200 RPM		1800 RPM	
									GPM OutPut	HP InPut	GPM OutPut	HP InPut
DOUBLE SHAFT REFUSE PUMP FOR HEIL												
C151-2.0	J20615	\$....	1-1/8 RD	24P12S	Rear	Both	2400	2000	25.0	30.0	38.0	45.0

MEDIUM SERIES DUMP PUMP

Medium series cast iron roller bearing dump pump - 2 (for intermittent operation only) or 3 (for intermittent or continuous operation) line plumbing hookup. Flows 19 to 39 GPM depending on pump RPM. Pressures to 2500 PSI. Speeds up to 2400 RPM. Either dual shaft (1" round) for PTO drive or single shaft. For direct mount (2 or 4 bolt B and 7/8-13 spline shaft.) Three-way three position control valve with built in relief set at 2000 PSI. G101 and G102 Relief is shim adjustable. Relief shims are in stock.

Dump Pump Part Number	Our Sequence Number	Price Per Piece	Max. Speed RPM	Max. Pressure PSI	Wt. Lbs.	Cubic Inch Per Revolution	Gallons Output & Horsepower Required at 2000 PSI					
							1200 RPM		1800 RPM		2400 RPM	
							GPM OutPut	HP InPut	GPM OutPut	HP InPut	GPM OutPut	HP InPut
G101-1-1.5	J20160	\$....	2400	2500	35	2.96	14.0	16.0	21.0	25.0	28.0	33.0
G101-1-20	J20170	2400	2500	38	3.94	19.0	22.0	29.0	34.0	39.0	46.0
G102-2-15R*	J20400	693.28	2400	2500	35	2.96	14.0	16.0	21.0	25.0	28.0	33.0
G102-2-15L*	J20404	693.28	2400	2500	35	2.96	14.0	16.0	21.0	25.0	28.0	33.0
G102-1-20R*	J20422	2400	2500	38	3.94	19.0	22.0	29.0	34.0	39.0	46.0
G102-1-20L*	J20423	2400	2500	38	3.94	19.0	22.0	29.0	34.0	39.0	46.0

LARGE SERIES DUMP PUMP

Large series cast iron roller bearing dump pump direct or remote mount 2 (for intermittent operation only) or 3 line operation. Flows to 48 GPM depending on RPM. Pressure to 2000 PSI. Speeds up to 1800 RPM. Either dual shaft (1" round) for PTO drive or single shaft for direct mount (4 bolt B and 7/8-13 spline shaft). Three-way three position control valve with built in relief set at 2000 PSI. Air shift available.

Dump Pump Part Number	Our Sequence Number	Price Per Piece	Max. Speed RPM	Max. Pressure PSI	Wt. Lbs.	Cubic Inch Per Revolution	Gallons Output & Horsepower Required at 1000 PSI					
							1200 RPM		1800 RPM		2400 RPM	
							GPM OutPut	HP InPut	GPM OutPut	HP InPut	GPM OutPut	HP InPut
C101D-20	J20020	\$....	1800	2000	70	5.60	25.0	29.0	38.0	44.0		
C101D-25	J20060	1800	2000	75	6.38	32.0	37.0	48.0	56.0		
C102D-20*	J20040	1800	2000	70	5.60	25.0	29.0	38.0	44.0		
C102D-25*	J20080	812.27	1800	2000	75	6.38	32.0	37.0	48.0	56.0		

* Direct Mount 4 Bolt B 7/8-13 Spline Shaft

AIR SHIFT KIT FOR C101 DUMP PUMPS

Part Number	Our Sequence Number	Price Per Piece	Description
314-9414-005	975080	\$....	Air Shift Kit for C101 & C102 with Actuator
308-9414-015	975090	Air Shift Kit for G101 & G102 with Toggle

ACCESSORIES

Part Number	Our Sequence Number	Price Per Piece	Description
314-0100-005	975070	37.71	Mounting Bracket for C101 Pad Mount Pumps ONLY
391-3283-052	9757572	6.93	Optional Sleeve for Three Line Installation Only For ALL Dump Pumps
391-1802-578	9757571	27.25	G101 and G102 Detent Kit
391-1802-579	MM55950	65.32	G101 and G102 Spring Return to Neutral Kit

CAUTION: The valve lever should be fitted with a locking device to prevent accidentally raising the bed should the operator forget to disengage the PTO for traveling. Never work under a raised dump body without first blocking it to prevent accidental lowering.

Prices subject to change without notice. **ASK FOR QUANTITY DISCOUNT**

1-800-228-9222 / e-mail: sales@baumhydraulics.com

Fax: 1-800-832-2522 / www.baumhydraulics.com / © Baum Hydraulics Corporation

BAUM HYDRAULICS CORPORATION

**COMMERCIAL HIGH PERFORMANCE
SINGLE GEAR MOTORS WITH ROLLER BEARING**

WHEN YOU NEED TO REPLACE A MOTOR. WE HAVE IT IN STOCK.

FIRST: Pick the flange type you need looking across drawing below.

SECOND: Pick either splined or round shaft under your drawing.

THIRD: Pick out your High Performance Motor that fits your need under your drawing.

REVERSIBLE SINGLE GEAR MOTORS - HIGH SPEED - HIGH PRESSURE

2 BOLT TYPE A
3-1/4" Round Pilot
4-3/16" Bolt Circle

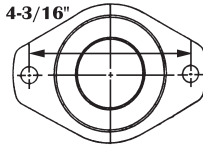

7/8" Rd. Shaft
M20X894XXX-30
M30X894XXX-30

7/8" 13 Spl. Shaft
M20X894XXX-25
M30X894XXX-25

1" Rd. Shaft
M20X894XXX-43
M30X894XXX-43

2 BOLT TYPE B
4" Round Pilot
5-3/4" Bolt Circle

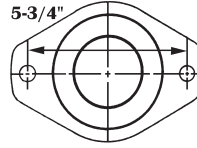

7/8" Rd. Shaft
M20X897XXX-30
M30X897XXX-30
M50X897XXX-30

1" Rd. Shaft
M20X897XXX-43
M30X897XXX-43

1-1/4" Rd. Shaft
M50X897XXX-11

7/8" 13 Spl. Shaft
M20X897XXX-25
M30X897XXX-25
M50X897XXX-25

1-1/4" 14 Spl. Shaft
M20X897XXX-7
M30X897XXX-7
M50X897XXX-7

2 BOLT TYPE C
5" Round Pilot
7-1/8" Bolt Circle

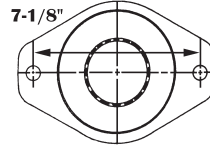

1-1/4" Rd. Shaft
M50X898XXX-11
M75X898XXX-11

1-1/4" 14 Spl. Shaft
M50X898XXX-7
M75X898XXX-7

4 BOLT TYPE B
4" Round Pilot
5" Bolt Circle

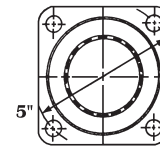

7/8" Rd. Shaft
M20X842XXX-30
M30X842XXX-30
M50X842XXX-30
M75X842XXX-30

1" Rd. Shaft
M20X842XXX-43
M30X842XXX-43

1-1/4" Rd. Shaft
M50X842XXX-11
M75X842XXX-11

7/8" 13 Spl. Shaft
M20X842XXX-25
M30X842XXX-25
M50X842XXX-25

1-1/4" 14 Spl. Shaft
M20X842XXX-7
M30X842XXX-7
M50X842XXX-7
M75X842XXX-7

4 BOLT TYPE C
5" Round Pilot
6-3/8" Bolt Circle

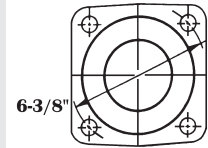

1-1/4" Rd. Shaft
M30X878XXX-11
M50X878XXX-11
M75X878XXX-11

1-1/4" 14 Spl. Shaft
M30X878XXX-7
M50X878XXX-7
M75X878XXX-7

Motors in this series are positive displacement to produce a definite speed at a particular rate of flow and give a certain value of torque at a particular pressure.

CUSTOM BUILT MOTORS BUILT DIFFERENT FROM STANDARD MOTORS SHOWN BELOW ARE MORE EXPENSIVE

Motor With ROUND Shaft & Roller Bearing Part Number	Motor With SPLINED Shaft & Roller Bearing Part Number	Max. Speed RPM	Port Size & Type & Location	Max. Pressure PSI	Gallons Output & Horsepower Required at 2000 PSI			
					1200 RPM		1800 RPM	
					GPM Input	HP Output	GPM Input	HP Output
M20A897MEAB05-30	M20A842MEAB05-25	2400	12P12P-E	3000	7	5	10	8
M20A842MEAB07-30	M20A842MEAB07-25	2400	12P12P-E	3000	9	8	13	12
M20A897BEIF10-30	M20A842BEIF10-25	2400	12P12P-E	3000	13	11	18	16
M20A842BEIF12-30	M20A897BEIF12-25	2400	12P12P-S	3000	16	14	23	21
M20A897BEYF15-30	M20A842BEYF15-25	2400	16P16P-S	3000	18	17	26	25
M20A842BEYF17-30	M20A842BEYF17-25	2400	16P16P-S	2500	21	20	30	29
M20A897BEYL20-30	M20A842BEYL20-25	2400	20P20P-S	2500	23	22	34	33
M30A897MEAB05-30	M30A842MEAB05-25	2400	12P12P-E	2500	7	5	10	8
M30A842MEAB07-30	M30A897MEAB07-25	2400	12P12P-E	2500	9	8	13	12
M30A897BEIF10-30	M30A897BEIF10-25	2400	12P12P-E	2500	13	11	18	16
M30A897BEIF12-30	M30A897BEIF12-25	2400	12P12P-S	2500	16	14	23	21
M30A897BEYF15-30	M30A842BEYF15-25	2400	16P16P-S	2000	18	17	26	25
M30A897BEYF17-30	M30A897BEYF17-25	2400	16P16P-S	2000	21	20	30	29
M30A842BEYL20-30	M30A842BEYL20-25	2400	20P20P-S	2000	23	22	34	33
M50A898BEIJ10-11	M50A897BEIF10-25	2400	12P12P-S	2500	15	13	22	19
M50A878BEIJ12-11	M50A842BEIF12-25	2400	12P12P-S	2500	19	17	27	26
M50A898BEYG15-11	M50A897BEYF15-25	2400	16P16P-S	2500	22	21	33	30
M50A878BEYJ17-11	M50A842BEYF17-25	2400	16P16P-S	2000	25	24	38	35
M50A898BEYL20-11	M50A878BEYL20-7	2400	20P20P-S	2000	30	28	44	41
M50A898BEYL22-11	M50A898BEYL22-7	2400	20P20P-S	2000	33	31	49	46
M50A878BEYL25-11	M50A878BEYL25-7	2400	20P20P-S	2000	37	35	54	49
2 BOLT C WITH SPLINE SHAFT		4 BOLT C WITH SPLINE SHAFT						
M75A898BEIF10-7	M75A878BEIF10-7	2400	12P12P-S	2500	27	20	38	28
M75A898BEYF12-7	M75A878BEYF12-7	2400	16P16P-S	2500	33	25	46	33
M75A898BEYF15-7	M75A878BEYF15-7	2400	16P16P-S	2500	38	31	54	45
M75A898BEYF17-7	M75A878BEYF17-7	2400	16P16P-S	2500	43	36	63	54
M75A898BEYL20-7	M75A878BEYL20-7	2400	20P20P-S	2000	49	42	71	62
M75A898BEYL22-7	M75A878BEYL22-7	2400	20P20P-S	2000	54	48	80	72
M75A898BEYL25-7	M75A878BEYL25-7	2400	20P20P-S	2000	60	54	87	79
M75A898BEYL27-7	M75A878BEYL27-7	2400	20P20P-S	2000	66	61	97	90
M75A898BEYL30-7	M75A878BEYL30-7	2400	20P20P-S	2000	72	68	103	99

DATA SHOWN MAY VARY WITH SPECIFIC UNIT AND TYPE OF OIL USED AND TEMPERATURE.

ASK FOR QUANTITY DISCOUNT

Prices subject to change without notice.

COMMERCIAL HIGH PERFORMANCE SINGLE GEAR MOTORS WITH TYPE BEARING BUSHING

K19

WHEN YOU NEED TO REPLACE A MOTOR. WE HAVE IT IN STOCK.

FIRST: Pick the flange type you need looking across drawing below.

SECOND: Pick either splined or round shaft under your drawing.

THIRD: Pick out your High Performance Motor that fits your need under your drawing.

REVERSIBLE SINGLE GEAR MOTORS - HIGH SPEED - HIGH PRESSURE

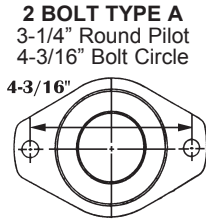

3/4" Rd. Shaft
M315A993XX-97
M11A993IEAXXX-24

7/8" Rd. Shaft
M315A993XX-66

2 BOLT TYPE AA
2" Round Pilot
3-1/4 Bolt Circle
M5A995IEAHXX-26

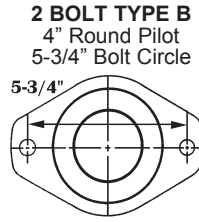

7/8" Rd. Shaft
M315A996XX-66
M330C897XX-30

1" Rd. Shaft
M330C897XX-43

1-1/4" Rd. Shaft
M350C897XX-11
M365C897XX-11

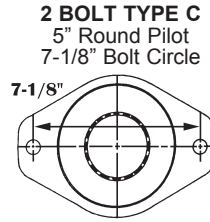

1-1/4" Rd. Shaft
M350C898XX-11
M365C898XX-11

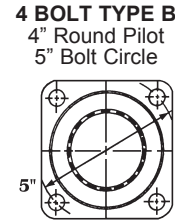

1-1/4" Rd. Shaft
M350C842XX-11
M365C842XX-11

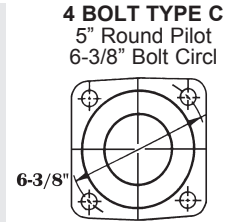

1-1/4" Rd. Shaft
M350C878XX-11
M365C878XX-11

M5 and M11

M315, M330, M350, and M365

Motors in this series are positive displacement to produce a definite speed at a particular rate of flow and give a certain value of torque at a particular pressure. Refer to the chart below for more information. Data shown may vary with specific unit and type of oil uses and temperature.

M5 and M11

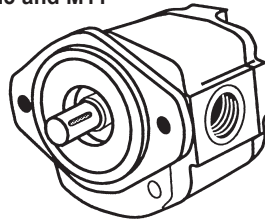

M315, M330, M350, and M365

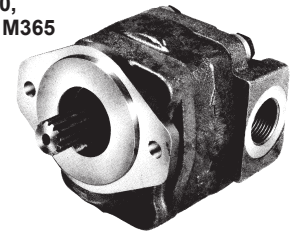

Motor With One Piece Shaft & Roller Bearing Part Number	Our Sequence Number	Motor Price Per Piece	Torque in Lbs.	Max. Speed RPM	Port Size & Type & Location	Max. Pressure PSI	Gallons Output & Horsepower Required at 3500 PSI					
							1200 RPM		1800 RPM		2400 RPM	
						GPM Input	HP Output	GPM Input	HP Output	GPM Input	HP Output	
M5A995IEAH04-26	J29070	\$....	127	4000	10S10S-S	4400	1.4	2.4	2.0	3.6	2.6	4.8
M5A995IEAH06-26	J29075	360.17	195	4000	10S10S-S	4400	2.1	3.7	3.0	5.6	3.9	7.4
M5A995IEAH08-26	J29080	394.40	255	4000	10S10S-S	4400	2.8	4.9	4.0	7.3	5.2	9.8
M5A995IEAH10-26	J29085	291.91	320	4000	10S10S-S	4000	3.5	6.1	4.9	9.1	6.5	12.2
M11A993HEAX16-24	J29091	559.22	510	4000	12S12S-S	4400	5.6	9.7	7.9	14.5	10.5	19.5
M11A993HEAX23-24	J29095	674.70	740	4000	12S12S-S	3700	8.1	14.0	11.4	21.0	15.1	28.0
On all M5 and M11 motors the 7/16 o-ring thread drain line port must be hooked up to low pressure return (less than 50 PSI) or to tank on its own.												
M315A993VNAB10-97	630	3000	16S16S-S	3500	7.9	11.9	11.0	17.1	14.2	21.2
M315A993VNAB15-97	945	3000	16S16S-S	3250	11.0	16.7	16.1	24.6	20.8	31.2
M315A993VNAB20-97	1090	3000	16S16S-S	2500	14.2	17.2	20.8	25.5	27.4	32.8
M330C842VCAB10-25	995	2400	20S20S-S	3500	12.5	18.9	17.5	28.4	22.5	37.9
M330C842VCAB12-25	1250	2400	20S20S-S	3500	15.0	23.8	21.5	35.7	28.0	47.6
M330C842VCAB15-25	1500	2400	20S20S-S	3500	17.5	28.6	25.5	42.8	33.0	57.1
M330C897VCAB17-43	1660	2400	20S20S-S	3250	20.0	31.6	29.0	47.4	38.5	63.2
M330C897VCAB20-43	1725	2400	20S20S-S	3000	22.5	32.8	33.0	49.3	43.5	65.7
M350C842VCAB10-25	1250	2400	20S20S-S	3500	17.0	23.8	23.5	35.7	30.0	47.6
M350C842VCAB12-25	1610	2400	20S20S-S	3500	20.0	30.7	28.5	45.9	37.0	61.3
M350C842VCAB15-25	1960	2400	20S20S-S	3500	23.5	37.3	33.5	55.9	43.5	74.6
M350C878VCAB17-11	2150	2400	20S20S-S	3250	27.0	40.9	38.5	61.4	50.0	81.9
M350C878VCAB20-11	2260	2400	20S20S-S	3000	30.0	43.0	43.5	64.6	57.0	86.0
M350C878CRAB22-11	2340	2400	24SF24SF-S	2750	33.5	44.6	48.5	66.8	63.5	89.1
M350C878CRAB25-11	2360	2400	24SF24SF-S	2500	37.0	44.9	53.5	67.4	70.0	89.9
M365C878VCAB10-11	1800	2400	20S20S-S	3500	23.5	34.3	33.0	51.4	42.5	61.7
M365C878VCAB12-11	2250	2400	20S20S-S	3500	28.0	42.8	40.0	64.3	52.0	78.1
M365C878VCAB15-11	2740	2400	20S20S-S	3500	33.0	52.2	47.0	78.3	61.0	95.2
M365C878VCAB17-11	3230	2400	20S20S-S	3500	37.5	61.5	54.0	92.3	70.5	113.3
M365C878VCAB20-11	3620	2400	20S20S-S	3500	42.5	68.9	61.0	103.4	80.0	128.0
M365C878CRAB22-11	3900	2400	24SF24SF-S	3250	47.5	74.3	68.0	111.4	90.0	133.3
M365C878CRAB25-11	3975	2400	24SF24SF-S	3000	52.0	75.7	75.0	113.5	98.5	139.0

Prices subject to change without notice. **ASK FOR QUANTITY DISCOUNT**

1-800-228-9222 / e-mail: sales@baumhydraulics.com

Fax: 1-800-832-2522 / www.baumhydraulics.com / © Baum Hydraulics Corporation

BAUM HYDRAULICS CORPORATION

COMMERCIAL PUMPS, MOTORS, and FLOW DIVIDERS

MADE FROM PARTS OR ALREADY ASSEMBLED
Commercial 15H, 25X, 37X, 30, 31, 50, 51, 75, 76, 315, 350, 365 Pumps and Motors
Below are examples of Commercial numbers: Please call for price and stock.
FOR REPAIR AND REPLACEMENT - CALL US

SINGLE UNIT

Commercial pumps and motors are available as single or multiple assemblies. The full assembly code for the finished unit combines individual codes for shaft end cover, port end cover, gear housing, and drive shaft. It is preceded by the letter P or M for pump or motor - and by a number to designate the series.

PUMP MODELS START WITH LETTER P;
MOTOR MODELS START WITH LETTER M

P25X SINGLE PUMP

Example Only: Assembly Code P25X 342 BE IT20-25

Pump	P	1. Shaft End Cover	342
Series	25	2. Port End Cover	BE
Model	X	3. Gear Housing	IT20
		4. Drive Shaft	25

M25X SINGLE MOTOR

Example Only: Assembly Code P25X 342 BE IT20-25

Motor	M	1. Shaft End Cover	942
Series	25	2. Port End Cover	BE
Model	X	3. Gear Housing	IT20
		4. Drive Shaft	25

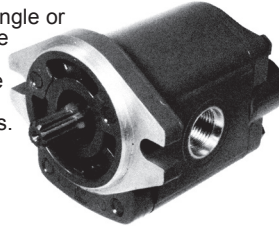

MULTIPLE UNIT

Multiple units are coded in the same manner except that additional designations for added sub-components must be included. Each section added to the single assembly requires a proper code for a bearing carrier, gear housing and connecting shaft.

Here is an example of an assembly code for a two-section 37X pump:

P37X MULTIPLE PUMP

Example Only: Assembly Code P37X 178 BY VZ20-7 B IL 15-1

Pump	P	1. Shaft End Cover	178
Series	37	2. Port End Cover	BY
Model	X	3. Gear Housing	VZ20
		4. Drive Shaft	7
		5. Bearing Carrier	B
		6. Gear Housing	IL15
		7. Connection Shaft	1

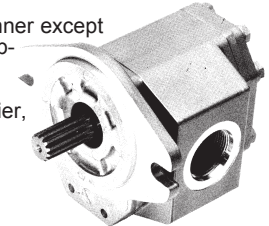

COMMERCIAL PUMP & MOTOR SEAL KITS, SHAFT SEALS, BEARINGS, & WEAR PLATES

Part Number	Series	Our Sequence Number	Price Per Piece
Seal Kits Pumps One Section			
391-1802-031	P15H	MM55858	\$21.93
391-1802-129	P25X	MM55875	23.62
391-1802-016	P37X	MM55850	26.69
CSK-P20A	P20A	EE3040	17.64
CSK-P20C	P20C	EE3050	33.70
391-1802-119	P30/31	MM55870	13.94
CSK-P30C/P31C	P30/31	EE3060	34.54
391-1802-137	P50/51	MM55881	17.31
CSK-P50C/P51C	P50/51	EE3080	33.24
391-1802-136	P75/76	MM55880	27.42
CSK-P315	P315	EE3065	22.74
391-1802-441	P330A	MM55941	19.42
CSK-P350	P350	EE3070	65.05
391-1802-494	P365	MM55945	37.42
391-1822-101	P5	97244064	51.32
P11-SK1VV	P11	9736649
8611-023-00N	PGP511	9717398	20.27
8611-023-Q1N	PGP511	9717397	34.21
391-1822-071	P17	97244060	38.90

Part Number	Series	Our Sequence Number	Price Per Piece
Shaft Seals Metal Clad Pumps			
391-2883-048	P15H	975940	\$7.74
391-2883-055	----	-----
391-2883-052	P37X	975945	19.15
391-2883-058	P20A	975947	2.93
391-2883-107	P20C	975957	13.64
391-2883-058	P30/31	975947	2.93
391-2883-107	P30/31	975957	13.64
391-2883-103	P50/51	975955	8.13
391-2883-133	P50/51	975966	15.00
391-2883-052	P75/76	975945	19.15
391-2883-151	P315	975969	5.79
391-2883-058	P330	975947	2.93
391-2883-103	P350	975955	8.13
391-2883-052	P365	975945	19.15
391-2883-178	P5	9736693	10.91
391-2881-181	P11	9736699	2.61
8301-019-00K	PGP511	9717395	5.84
9352-061-00T	PGP511	9717394	5.42
391-2883-058	P17	975947	2.93

Part Number	Series	Our Sequence Number	Price Per Piece
Wear Plates Two Required Per Section			
391-2185-907	P15H	975820	\$66.48
391-2185-912	P25X	975822	35.77
391-2185-909	P37X	975821	27.77
391-2185-913	P20A	975823	47.43
391-2185-913	P20C	975823	47.43
391-2185-913	P30/31	975823	47.43
391-2185-913	P30/31	975823	47.43
391-2185-912	P50/51	975822	35.77
391-2185-912	P50/51	975822	35.77
391-2185-920	P75/76	975824	85.11
391-2185-963	P315	975830	34.99
391-2185-956	P330	975828	30.93
391-2185-957	P350	975829	55.10
391-2185-955	P365	975827	150.30

Part Number	Series	Our Sequence Number	Price Per Piece
Seal Kits Motors One Section			
391-1801-014	M15H	MM55813	\$13.29
391-1801-015	M25X-I	MM55814	97.97
391-1801-009	M37X	MM55812	47.08
CSK-M20A	M20A	EE3000	60.60
CSK-M20C	M20C	EE3010	125.78
391-1801-032	M30/31	MM55822	46.36
CSK-M30C/M31C	M30/31	EE3020	126.62
CSK-M50C	M50/51	EE3032	57.93
391-1801-063	M50/51	MM55842	55.97
391-1802-143	M75/76	MM55885	47.80
CSK-M315	M315	EE3029	101.62
CSK-M330	M330	EE3030	116.34
CSK-M330C	M330	EE3031	181.52
391-1801-115	M350	EE3034	127.47
CSK-M350C	M350	EE3033	111.24
CSK-M365	M365	EE3035	163.45
391-1801-304	M5	9719695	86.18
8301-023-Q1N	PGM511	9717396	39.10
M511-SKIVV/LG	PGM511	97366493	73.32
M511-SKIVV/MG	PGM511	97366497	40.73

Part Number	Series	Our Sequence Number	Price Per Piece
Shaft Seals Metal Clad Motors			
391-2883-096	M25X	975953	\$30.44
391-2883-094	M37X	975952	37.16
391-2883-119	M20A	975962	31.57
391-2883-126	M20C	975964	75.03
391-2883-119	M30/31	975962	31.57
391-2883-126	M30/31	975964	75.03
391-2883-186	M50/51	984056	31.46
391-2883-115	M50/51	975959	42.28
391-2883-094	M75/76	975952	37.16
391-2883-119	M330	975962	31.57
391-2883-126	M330	975964	75.03
391-2883-115	M350	975959	42.28
391-2883-186	M350	984056	31.46
391-2883-094	M365	975952	37.16

Part Number	Series	Our Sequence Number	Price Per Piece
Roller Bearings Four Required Per Section			
391-0381-062	M15H	975757	\$17.32
391-0381-059	M25X	975759	22.64
391-0381-060	M37X	975758	20.74
391-0381-068	M20A	975760	18.73
391-0381-068	M20C	975760	18.73
391-0381-068	M30/31	975760	18.73
391-0381-068	M30/31	975760	18.73
391-0381-059	M50/51	975759	22.64
391-0381-059	M50/51	975759	22.64
391-0381-060	M75/76	975758	20.74
391-0482-195	M315	975778	6.00
391-0482-306	M330	975779	20.34
391-0482-306	M330	975779	20.34
391-0482-308	M350	975781
391-0482-308	M350	975781	14.32
391-0482-307	M365	975780	22.42

Part Number	Series	Our Sequence Number	Price Per Piece
Lip Seals Motor			
391-2883-184	M5	9736645	15.97
391-2883-185Z hi	M11	9736647	12.93
8301-020-00M	PGM511	97366485
335-0900-748	PGM511	97366486
9411-601-00N	PGM511	9717393	9.15
9411-601-00N	PGM511	9736648

ASK FOR QUANTITY DISCOUNT Prices subject to change without notice.



PUMP AND MOTOR SEAL KITS



K21

Part Number For Series Our Sequence Number Price Per Piece

GRESEN VALVE SEAL KITS

K-2001A	SP-SPK 1 Spool	EE2420	\$1.24
K-2002B	SP-SPK 2 Spool	EE2422	1.70
K-2003A	SP-SPK 3 Spool	EE2423	1.90
K-3001C	300-400	EE24995	8.43
K-6005	V20 RC Cyl. Port Seal Kit	EE2270	4.42
K-6006C	WC Main Relief Seal Kit	EE2271	0.91
K-6027A	V20 Per Spool	EE2330	10.47
K-6121B	V20 Seal Kit	EE2365	1.11
K-6028C	6721 Float Section Seals	EE2331	11.48
K-6074	V20 Seal Kit Solenoid Adapter	EE2350	0.89
K-6077	V20 Seal Kit Solenoid Valve Cart.	EE2360	1.07
K-6184	V20 Seal Kit Solenoid Bldg. Valve	EE2370	1.45
K-7001B	25P Per Spool	EE2372	1.53
K-7501	V30 Per Spool	362762
K-12500	V50 Per Spool	EE2385	3.87
K-12010	V70 Per Spool	362922	53.56
K-13001A	S50 Seal & Snap Ring	EE2388	0.31
K-14001A	S75 & DS75 Seal & Snap Ring	EE2389	1.02
K-15001A	S100 Seal & Snap Ring	EE2390	0.77
K-19003	WH Relief Seals	EE2400	0.92
K-19005	RP51 Relief Seals	EE2404	2.19
K-6061	V20 Pressure Detent Seals	362750	14.33
K-28078	25P-42 Seal Kit PSI Reducing	EE2499	1.74
K-27004	WH Relief Seals	EE2498	2.01
K-12011	V70 Section Seals	EE2380	0.25

GRESEN PUMP SEAL KITS

K-8002B	TB Pump	362780	115.01
K-9003F	TC Pump	362840	155.32
K-10002F	DCB Pump	362900	180.14

PRINCE PUMP SEALS KITS

PMCK-PMHP10	Hand Pump	EE2145	40.49
PMCK-PTO-1	HCI Pump	100725
PMCK-PTO-1A	HCI Pump with 3 Ports	100724	108.45

TRW ROSS MOTOR SEAL KITS

SK000090	MG-MF,MK	708674	78.07
SK000092	MB-ME	708678	106.99
SK000093	MB-ME Viton Seal	708680	193.74
SK000183	Same as Nikols 2263	7086781	147.00

CROSS VALVE SEAL KITS

2V0001	CA1 1 Spool	725504
2V0002	CA2 2 Spool	EE2100	2.35
2V0008	BA1 1 Spool	EE2112	4.85
2V0009	BA2 2 Spool	EE2114	5.73
2V0010	BA3 3 Spool	EE2116	6.89

SUNDSTRAND PUMP & MOTOR SHAFT SEAL KITS

9008000-7505	15 Pump	BB0005	8.65
9008000-7506	15 Motor	BB0015
9008000-9004	18 Motor	BB0025	56.48
9510189	20-21-22	BB0030	185.13
9510190	23	BB0035	188.65

SUNDSTRAND PUMP & MOTOR OVERHAUL SEAL & GASKET KITS

9510354-0001	15 Pump	BB0040	133.30
9510354-003	15 Motor	BB0045	32.92
9510355-003	18 Pump	BB0050	390.30
9510355-0001	18 Motor	BB0055	111.81
9510224	20 Pump	BB0060	45.29
9510225	20 Motor	BB0065	20.75
9510227	21 Pump	BB0070	45.29
9510228	21 Motor	BB0075	26.66
9510230	22 Pump	BB0080	62.21
9510231R	22 Motor	BB0085	57.76
9510233	23 Pump	BB0090	122.07
9510234	23 Motor	BB0095	26.66

INDIVIDUAL SEALS SOLD IN G SECTION OF CATALOG

PLEASE TELL US OTHER SEAL KITS OR SEALS OR SNAP RINGS OR CABLES YOU NEED! SEND US A SAMPLE KIT OR A SAMPLE OF WORN PARTS AND WE WILL SUPPLY THEM. WE HAVE THEM IN STOCK AND CAN SHIP AT ONCE.

Part Number For Series Our Sequence Number Price Per Piece

EATON PUMP & MOTOR SHAFT SEAL KITS

990231	39 to 54	BB0505	\$376.56
990195	76	BB0510	364.70
93955 C/R	7	BB0515	15.23
93895 C/R	7 Control Shaft	BB0525	11.43
92999 C/R (2)	11 Control Shaft	BB0530	4.70

EATON PUMP & MOTOR OVERHAUL SEAL KITS

990088	39 Pump	BB0700	201.82
990089	46 Pump	BB0705	201.82
990090	54 Pump	BB0710	276.45
990091	76 Pump	BB0715	201.82
990092	39 Motor	BB0720	140.78
990093	46 Motor	BB0725	235.47
990094	54 Motor	BB0730	140.78
990095	76 Motor	BB0735	159.81

CHAR-LYNN MOTOR SEAL KITS

60580	Sealkit for Char-Lynn J Series Motors	BB10276	114.61
60036	H (Old) -005	BB1005	59.35
60023	H-007	BB1010	75.87
60042	S-006, S-005	BB1015	98.17
60026	S-007	BB1020	78.10
60533	S-008	BB1025	73.00
61252	2000-002, 3, 4, 5	BB1030	123.22
61236	4000-004 Shaft Seals	BB1035	64.37
61234	4000-004, 6 Rear Seals	BB1040	52.73
61281	4000-006	BB1042	131.40
61104	6000-002, 3, 4 Shaft Seals	BB1045	117.11
61105	6000-002, 3, 4 Rear Seals	BB1050	41.21
6406	10,000 Shaft Seals	BB1055	90.58
6405	10,000 Rear Seals	BB1060	50.33
61237	6000-005, 6 Shaft Seals	BB1031	80.52
61258	2000-006	BB1032	123.54
61238	6000-005, 6 Rear Seals	BB1043	57.30
60539	S-009, S-010	BB1026	89.76
60540	H-008, 009, A-001, A-002, A-003	BB1027	83.48
60564	S-011, R-002, T-001	BB10275	107.97
61002	4000-003 Rear Seals	BB1028	29.92
61004	4000-003 Front Seals	BB1029	70.29
64418	211-212 P/S w/o Intregal Column	BB1053	85.09
21122	S101, 207-XXXX-006	MM05022	5.21
5241	1060 Valve Seals	MM05021	5.19
9057-001	Pressure Seal for H-007	824030	20.92
9057-009	Shaft Seal for 2000-006	824032	55.60
9057-014	Pressure Seal for 22000-002 FL
9121-002	Dust Seal for Small Motors	824036	15.30
9900101-000	Seal Kit S012 S Series	BB1065	94.17

The prefix of Char-Lynn Motors part number indicate the series and the suffix indicates the design number

"2000" Series Motor has 104 & 105-XXX-OOX Part Number
 "4000" Series Motor has 109 & 110 & 111-XXX-OOX Part Number
 "6000" Series Motor has 112 & 113 & 114-XXX-OOX Part Number
 "10000" Series Motor has 119 & 120 & 121-XXX-OOX Part Number
 "H" Series Motor has 101-XXX-OOX Part Number
 "S" Series Motor has 103-XXX-OOX Part Number
 "A" Series Motor has 130-XXX-OOX Part Number
 "R" Series Motor has 146-XXX-OOX Part Number
 "T" Series Motor has 158-XXX-OOX Part Number

CESSNA PUMP SHAFT SEAL KITS

20200-154	24200	824001	17.24
21070-85	24500	824005	11.25
15147-281	24000	824009	10.28
16232-16	74111, 74118, 74600	824021	25.95
84-7235	70422, 70423, 70252, 74418		
	PPV248, MF204/248	824023	17.26
16253-16	70142, PPV124, 74600 DBL	824025	14.87
16232-22	70523, PCPFC421	824027	46.15
84-7641	74704, ME878

WHITE MOTOR SEAL KITS

PS222001	RS Motor mfg. prior 1988	724080
PS222002	RS Motor mfg. after 1988	7240805
PE444001	RE Motor mfg. prior 1988	724081
PE444002	RE Motor mfg. after 1988	724077
500444112B	RE Motor mfg. after 2007	724082

Prices subject to change without notice. **ASK FOR QUANTITY DISCOUNT**

1-800-228-9222 / e-mail: sales@baumhydraulics.com
 Fax: 1-800-832-2522 / www.baumhydraulics.com / © Baum Hydraulics Corporation

BAUM HYDRAULICS CORPORATION

PRINCE GEAR PUMPS HIGH SPEED - HIGH PRESSURE

FIRST: Pick the flange type you need looking across drawing below.

SECOND: Pick either splined or round shaft under your drawing.

THIRD: Pick out your High Performance Pump that fits your need in the chart below.

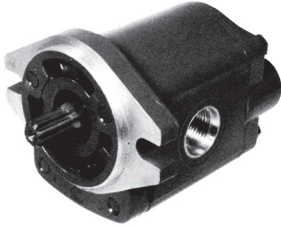

2 BOLT TYPE A
3-1/4" Round Pilot
4-3/16" Bolt Circle

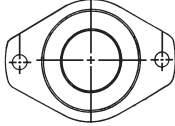

2 BOLT TYPE B
4" Round Pilot
5-3/4" Bolt Circle

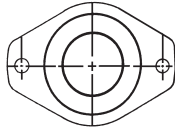

Pump With ROUND Shaft Part Number	Our Sequence Number	Price Per Piece	Gear Width Inches	Max. Speed RPM	Port Size & Type & Location	Max. Pressure PSI	Cubic Inch Per Revolution	Gallons Output & Horsepower Required at 2000 PSI			
								— 1200 RPM —		— 1800 RPM —	
								GPM Output	HP Input	GPM Output	HP Input
2A 5/8 RD - CCW											
SP20A8A9H2L	100614	\$363.91	.43	4000	12S10S-S	3000	.49	2.5	3.3	3.8	4.9
SP20A9A9H2L	100622	363.91	.48	4000	12S10S-S	3000	.55	2.9	3.8	4.4	5.7
SP20A11A9H2L	100630	363.91	.59	4000	12S10S-S	3000	.67	3.5	4.6	5.3	6.9
SP20A14A9H2L	100638	369.60	.75	4000	12S10S-S	3000	.85	4.4	5.7	6.6	8.6
SP20A16A9H2L	100646	369.60	.86	4000	12S10S-S	3000	.98	5.0	6.5	7.5	9.8
SP20A20A9H2L	100654	403.65	1.07	3500	16S12S-S	3000	1.22	6.4	8.3	9.6	12.5
SP20A23A9H2L	100662	407.27	1.23	3500	16S12S-S	3000	1.40	7.3	9.5	11.0	14.3
SP20A27A9H2L	100670	402.02	1.45	3500	16S12S-S	3000	1.65	8.5	11.1	12.8	16.6
2A 5/8 x 9 SPL. - CW											
SP20A8A9H9R	100616	\$363.91	.43	4000	12S10S-S	3000	.49	2.5	3.3	3.8	4.9
SP20A9A9H9R	100624	363.91	.48	4000	12S10S-S	3000	.55	2.9	3.8	4.4	5.7
SP20A11A9H9R	100632	363.91	.59	4000	12S10S-S	3000	.67	3.5	4.6	5.3	6.9
SP20A14A9H9R	100640	369.60	.75	4000	12S10S-S	3000	.85	4.4	5.7	6.6	8.6
SP20A16A9H9R	100648	407.29	.86	4000	12S10S-S	3000	.98	5.0	6.5	7.5	9.8
SP20A20A9H9R	100656	391.90	1.07	3500	16S12S-S	3000	1.22	6.4	8.3	9.6	12.5
SP20A23A9H9R	100664	395.40	1.23	3500	16S12S-S	3000	1.40	7.3	9.5	11.0	14.3
SP20A27A9H9R	100672	402.02	1.45	3500	16S12S-S	3000	1.65	8.5	11.1	12.8	16.6

DATA SHOWN MAY VARY WITH SPECIFIC UNIT AND TYPE OF OIL USED AND TEMPERATURE.

PRINCE PUMPS

HCI PUMPS - Features include self-adjusting wear plate, run-fitted aluminum body, roller bearings, internal spline with thru-drive feature, high-tensile cast iron end plates. Measures 8-3/4" high, 6-1/2" wide, and 6" deep. Use FLR215-9LDNH (10 micron) filter and DVLR-64 relief valve.

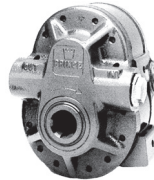

PUMP APPLICATIONS - Aluminum PTO pumps for slow speed applications. Cast iron PTO pumps for motor/ high speed applications

HCI Part Number	Max. RPM	GPM at 2000 PSI at Max. RPM	HP Input at 2000 PSI	O-Ring Inlet	O-Ring Outlet	Recommended Hose Size (inch)	
						Inlet	Outlet
With 1-5/16" O-Ring Thread Inlet and 1-1/16" O-Ring Thread Outlet							
HC-PTO-1A	540	21.0	32.1	1-5/16	1-1/16	1-1/4	3/4
HC-PTO-2A	540	11.4	18.1	1-5/16	1-1/16	1	3/4
HC-PTO-7A	540	7.4	11.9	1-5/16	1-1/16	1	3/4
HC-PTO-3A	1000	22.4	34.3	1-5/16	1-1/16	1-1/4	3/4
HC-P-K11	1000	40.0	58.8	1-5/8	1-5/16	2	1

Pipe Thread Part Number	Internal Splined Shaft	Our Sequence Number	Price Per Piece
-------------------------	------------------------	---------------------	-----------------

ALUMINUM HYDRAULIC PTO PUMPS

HC-PTO-1A	1-3/8	6 spline	100710	\$914.21
HC-PTO-2A	1-3/8	6 spline	100712	708.75
HC-PTO-7A	1-3/8	6 spline	100718	780.82
HC-PTO-3A	1-3/8	21 spline	100714	1012.02
HC-P-K11	1-3/8	21 spline	100720	1019.48

CAST IRON HYDRAULIC PTO PUMPS

HC-PTO-1AC	1-3/8	6 spline	100711	1195.14
HC-PTO-2AC	1-3/8	6 spline	100713	994.46
HC-P-K11C	1-3/8	21 spline	100719	1144.70

PMCK-PTO-1A Seal Kit for 3 port pump	100724	74.56
--------------------------------------	--------	-------

WARNING - IMPORTANT

PUMPS REQUIRE LARGE SEPARATE DVLR-64 RELIEF VALVE with 3/4 inch ports. Relief valves with 1/2 inch ports and relief valves built into control valves **ARE NOT LARGE ENOUGH**

Pumps require **WIRE REINFORCED SUCTION HOSE** that will not collapse, of 1-1/4" or 1-1/2" size.

Put Filter in **RETURN LINE BETWEEN CONTROL VALVE AND TANK**. Use 12 gallon tank for HC-PTO-2A and HP-PTO-7A. Use 20 gallon tank for HC-PTO-1A and HC-PTO-3A.

HOW TO SELECT A PUMP

Enter the chart below with the speed, revolutions per minute (RPM) at which you wish to operate your pump. The figures beside each of the pump sizes indicate the gallons per minute (GPM) output and the horsepower required from each size at that speed.

Example: You want to run your pump at 540 RPM and you desire about 21 GPM output. Enter the chart with 540 RPM and look down to 21 GPM output. A number HC-PTO-1A pump will produce 21 GPM output at 540 RPM at 2000 PSI pressure. Be sure this GPM output is enough to operate your motor at the speed desired.

Pump Number	Gallons Output & Horsepower Required at 2000 PSI			
	540 RPM		1000 RPM	
	GPM Output	HP Input	GPM Output	HP Input
HC-PTO-1A	21.0	32.1		
HC-PTO-2A	11.4	18.1		
HC-PTO-7A	7.1	11.9		
HC-PTO-3A			22.4	34.3

Pump Number	SPECIFICATIONS	
	Maximum Speed RPM	Maximum Pressure PSI
HC-PTO-1A	540	2250
HC-PTO-2A	540	2250
HC-PTO-7A	540	2250
HC-PTO-3A	1000	2250

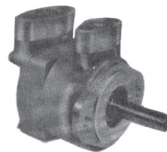

GRESEN HYDRAULIC VANE PUMPS

IMPORTANT: Relief Valve Required. Hydraulic relief valves must be used with all vane type pumps.

Pump Number	Wt. Lbs.	Our Sequence Number	Price Per Piece
TB6-75-50K-CCW	11	343050	\$717.75
TB9-100-75K-CCW	11	343080	877.25
TB12-100-75K-CCW	11	343100	826.38
TC12-125-75B-CCW	16-1/2	343130	827.86
TC16-125-100B-CCW	16-1/2	343150	1501.49
TC20-125-100B-CCW	16-1/2	343160	809.38
TC24-125-100B-CCW	16-1/2	343170	1501.58

ASK FOR QUANTITY DISCOUNT Prices subject to change without notice.